

GTT4010

Grain Bagger

AKRON[®]





AKRON[®]

GTT4010 GRAIN BAGGER

User's Manual Operation, Maintenance and Spare Parts



Code: 133100

Edition: July 2016

Review: 2016/001

Due to the continuing improvements in the design and manufacture of **AKRON[®]** products, **MICRÓN FRESAR S.R.L.** reserves the right to modify components and/or specifications without prior notice.

1. INTRODUCTION

This user's manual describes the functions and components of the **AKRON®** model **GTT 4010** grain bagger. The machine's operation and maintenance instructions are detailed here, as well as the necessary safety recommendations. The information provided in this manual is fundamental for the efficient and safe operation of the machine. This documentation is included in order to guarantee its optimal operation. This is why this manual should be available at all times either together with the machine or at least within the operators' and supervisors' reach.

1-a. The Purpose of the Machine

The **AKRON® GTT 4010** grain bagger is a state-of-the-art machine for storing grain in plastic grain bags according to cutting-edge trends in this type of operations. This design enables the machine to be completely dismantled in order to minimize its volume for transport between countries.

The machine's simple design concept reduces its maintenance requirements to a minimum and guarantees its optimum operation under a variety of conditions. However, it must be noted that this grain bagger has been designed exclusively for routine farm duties and that the guarantee will be valid only as long as the machine is used respecting the operation procedures described in the present manual.

For operating this machine and for any maintenance tasks or repairs, the instructions given in the present manual and in any other documentation supplied by the manufacturer must be followed. Special attention must be paid to safety precautions and recommendations, as well as all the pertinent local Occupational Health & Safety laws in force.

Any arbitrary modification carried out on the machine or its components will release the manufacturer from any responsibility arising from damage or injury that may occur as a result of such modification.

2. INDEX

1. Introduction	5
1-a The Purpose of the Machine.	5
3. Safety	9
3-a Attitude Toward Safety	9
3-b "ATTENTION" Symbol and Signal Words	9
3-c Personal Protective Equipment	10
3-d Safety Warnings	10
3-e Risk Analysis	10
4. Receiving the Machine	15
4-a Identification of your grain bagger	15
4-b Contact Information	15
4-c General Comments on Grain Storage in grain bags	15
4-d Operation Principles	15
5. Preparation and Setup	17
5.a Recommendations to Ease Subsequent Extraction	17
5.b Prior Checks in the Field	17
5.c Prior Checks on the Machine	17
5.d Machine Parking	17
5.e Machine Positioning	19
5.f Adjusting the brake system	19
5.g Grain bag Preparation and Mounting	19
5.h Final Adjustments Before Starting the Bagging	19
6. Bagging Procedure	25
6-a Operation Start-up	25
6-b Operation Parameters	26
6-c Protection against Overloads	26
6-d Interruptions During Bagging	26
6-e Operation at the End of the Grain Bag	27
6-f Closing the Grain Bag	27
7. Maintenance	29
7-a Maintenance Schedule	30
7-b Maintenance after Receiving the Machine	30
7-c Lubrication	30
7-d Replacement of Parts Subject to Wear	30
7-e Brake Fluid	30
7-f Wear Prevention on Flexible Pipes	30
7-g Tire Change	31

8. Machine Transportation and Storage	33
8-a Preparation of the Machine for Transport	33
8-b Transportation	33
8-c Machine Storage	34
9. Specifications	35
10. Product Dismantling and Disposal	37
11. Guarantee Terms	39
12. Spare Parts List	41
12-a Information for Obtaining Spare Parts	41
13. Parts subject to normal wear and tear	89
14. User's Notes	91

3. SAFETY

Even though the machine's operation is simple and safe, it is essential that all grain baggers operators and supervisors read this user's manual and have an in-depth knowledge of its contents. In this way, situations of danger will be avoided for the operator, third parties and any goods in the surrounding area.

There must be a written record of when the operators are trained in every detail of the machine's operation.

3-a. Attitude Toward Safety

Just as with the operation of any other machine, what is most important for preventing accidents of any kind is the positive attitude of operators and supervisors toward safety. As well as observing the manufacturer's recommendations, the habit must be developed of foreseeing and analyzing every possible contingency that could arise during the operation of the machine. Even though it is impossible to foresee all possible situations, this habit helps to prevent the large majority of hazardous situations.

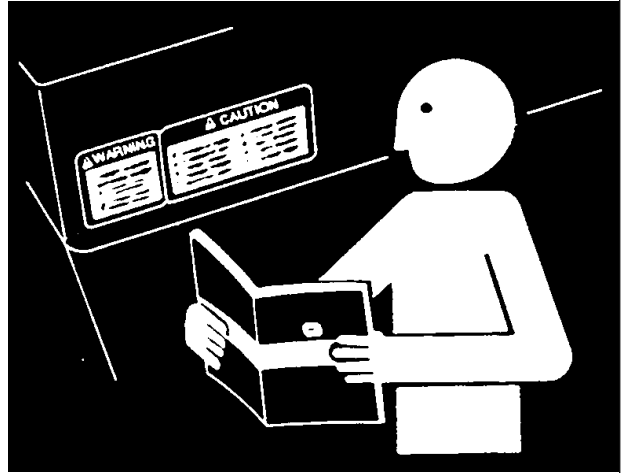

3-b. "ATTENTION" Symbol and Signal Words

Throughout the present manual, the "Attention" symbol is used to indicate risk situations for the operator, the machine, other equipment or other people.

This symbol will appear together with certain signal words depending on the relative seriousness of each risk situation.

DANGER: This identifies an imminent hazardous situation whose consequences may cause death or serious injuries if not avoided.

WARNING: This identifies a potential hazardous situation whose consequences may cause death or slight to moderate injuries if not avoided.

IMPORTANT: This describes a particular situation where the machine could be damaged or its normal operation could be affected.







3-c. Personal Protective Equipment

Avoid wearing loose clothing and always use the proper safety elements according to the type of job.

Long term exposures to high levels of noise can harm your ears. Wear ear protection to protect yourself from excessive noise.

Operating this equipment safely requires the full attention of the operator. Do not wear radio or music headphones while operating the machine.

Situation	Personal Protective Equipment			
				
Tractor driver	✓	✓		
Machine operator	✓	✓	✓	✓

3-d. Safety Warnings

On different parts of the machine and on its accessories you will find decals with accident prevention symbols which must be considered as part and extension of the instructions detailed in this manual. Special care must be taken to ensure these decals are present and legible during the entire working life of the machine.

If for any reason any of these gets lost or becomes illegible through wear, it is important to replace it immediately, indicating its corresponding code. To ask for a replacement decal, please contact either the manufacturer using the information given in 4-b "Contact information", or your local Technical Representative.

3-e. Risk Analysis

The risk situations that typically arise during the operation of this machine are detailed below. Recommendations are made that are of vital importance for the safety of the machine operators, of other workers nearby, and the machine itself.

The pictograms used are taken from IRAM standard 8075 "Tractors, agricultural and forestry and green space maintenance machinery - Safety signs and hazard pictograms - General principles and features". For more details, their location on the machine is shown in the following picture.

Risk situations:

- During machine transport

Particular recommendations:

- When transporting the bagging machine, stay below its speed limit for safety reasons



1

Risk situations:

- During bagging operation

Particular recommendations:

- Keep a safe distance from the machine.



2

Risk situations:

- During machine transport
- During bagging operation

Particular recommendations:

- Never stand or travel on the machine's structure.



3

Risk situations:

- When operating the machine

Particular recommendations:

- Observe the warnings indicated in the pictogram in order to avoid accidents



4

THIS STICKER MEETS THE REQUIREMENTS OF NORM IRAM 8075 016135

Risk situations:

- When operating the machine or performing maintenance tasks

Particular recommendations:

- Carefully read the operator's manual so as to become acquainted with its features and operation.



5

Risk situations:

- During grain bag preparation
- When performing maintenance tasks

Particular recommendations:

- Stop the motor and remove the key before performing setup or maintenance tasks.



6

Safety decals



7

Cardan coupling position

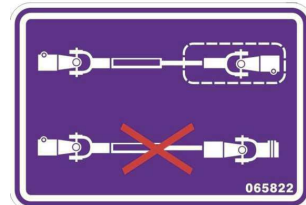

8

Risk situations:

- During bagging operation

Particular recommendations:

- Do not open or take away the safety protections while the motor is running.



9

Identification plate



10

Maximum 540 RPM



11

Risk situations:

- While uncoupling the machine from the tractor, the towbar lifts abruptly.

Particular recommendations:

- Observe the pictogram's indications by installing the support leg before uncoupling the machine.



12

Risk situations:

- During bagging operation

Particular recommendations:

- Do not stand within reach of the auger or introduce your hand while the motor is running.



13

Risk situations:

- During machine positioning
- During bagging operation

Particular recommendations:

- Never use the driveshaft without its protector.
- Never cross over the driveshaft while it is coupled.
- Use, maintain or repair the coupling according to the manual's indications.



14

Risk situations:

- When parking the machine on a slope

Particular recommendations:

- Apply the brake to prevent the machine from moving.



15

Maintenance



16

Hydraulic Brakes



17

Cradle latch





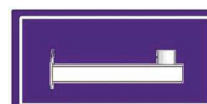

18

Support leg

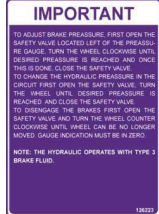

19

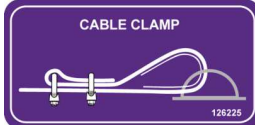
<p>Lifting jack</p>	 <p>SUPPORT POINT FOR HYDRAULIC JACK</p> <p>182120</p>	<p>20</p>
<p>Operating the winch.</p>	 <p>IMPORTANTE</p> <p>NO SEGUIR GIRANDO EL MALACATE CON PERCHA A TOPE</p>	<p>21</p>
<p>Hydraulic Pump</p>		<p>22</p>
<p>Maintenance.</p>	 <p>IMPORTANT</p> <p>TO ADJUST BRAKE PRESSURE: FIRST OPEN THE SAFETY VALVE (LOCATED LEFT OF THE PRESSURE GAUGE). TURN THE WHEELS DOWN UNTIL DESIRED PRESSURE IS REACHED AND ONCE THIS IS DONE CLOSE THE SAFETY VALVE.</p> <p>TO CHANGE THE HYDRAULIC PRESSURE IN THE CIRCUIT: FIRST OPEN THE SAFETY VALVE, TURN THE WHEELS UNTIL DESIRED PRESSURE IS REACHED AND CLOSE THE SAFETY VALVE.</p> <p>TO DISPERSE THE BRAKES: FIRST OPEN THE SAFETY VALVE AND TURN THE WHEEL COUNTER CLOCKWISE UNTIL WHEELS CAN BE NO LONGER MOVED. GAUGE INDICATION MUST BE IN ZERO.</p> <p>NOTE: THE HYDRAULIC OPERATES WITH TYPE 3 BRAKE FLUID.</p> <p>188333</p>	<p>23</p>
<p>Risk of injury or accident.</p>	 <p>WARNING</p> <p>RISK OF ACCIDENT OR INJURIES</p> <p>DO NOT STAND IN THE WAY OF THE CRADLE WHILE IT IS BEING OPERATED.</p> <p>128224</p>	<p>24</p>
<p>Cable clamp</p>	 <p>CABLE CLAMP</p> <p>128225</p>	<p>25</p>

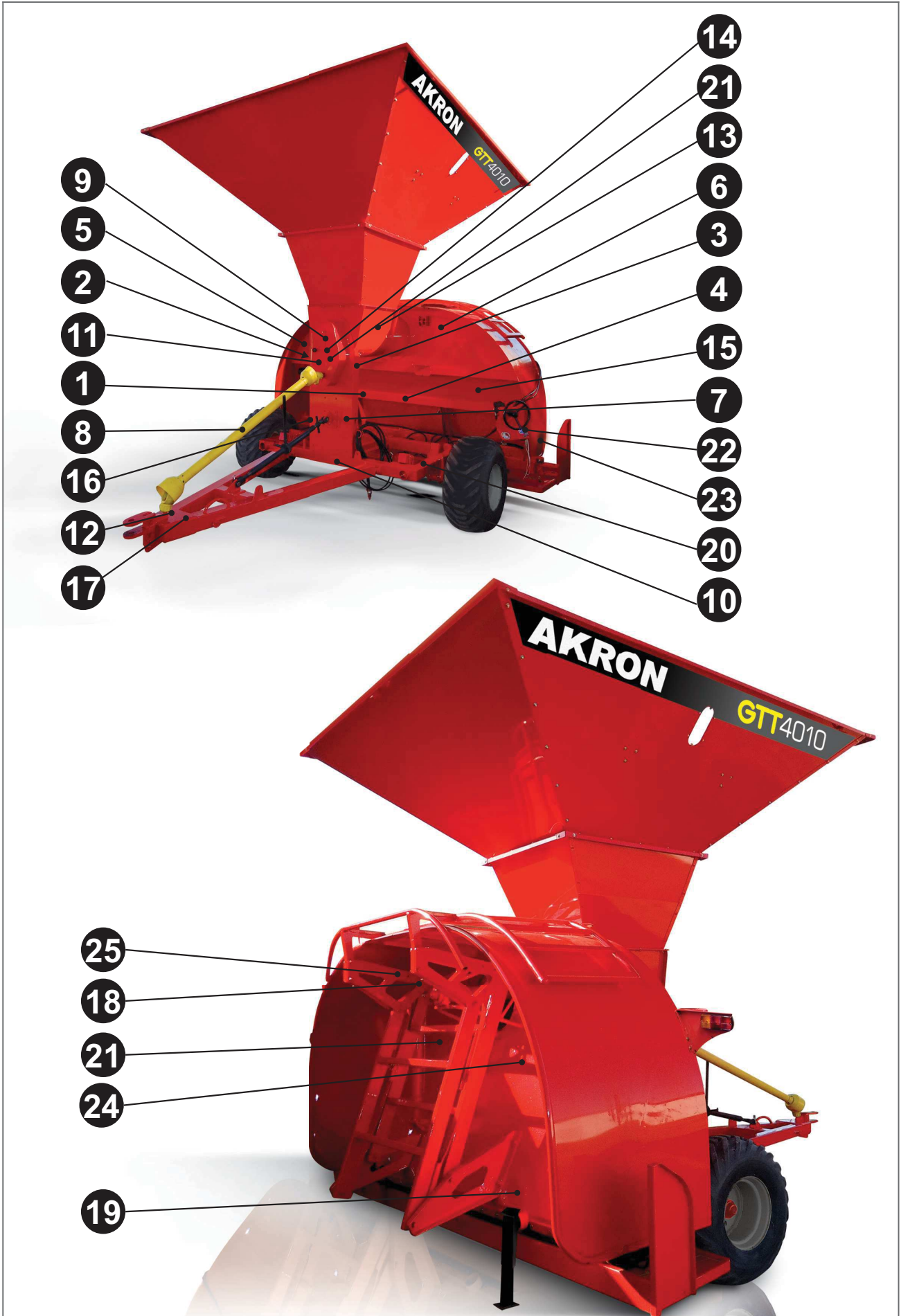

4. RECEIVING THE MACHINE

The **AKRON® GTT 4010** grain bagger is delivered almost ready for operation. Only a number of checks about issues related to transport must be made upon receiving the machine:

- 1) If the machine is delivered on a truck or similar vehicle, check that all the slings and elements used to fix the machine to the transport are removed.
- 2) Check that the tire pressure is at the values recommended in section 7 “Maintenance”.
- 3) Check that all the main machine components are present and in good condition. The spare parts list included at the end of this manual makes a good checklist.
- 4) All the safety guards and protections should be present and in good condition (e.g., the transmission cover on the tractor side, the driveshaft cover, etc.).

4-a. Identification of your Grain Bagger

When ordering replacement parts or requesting technical assistance or information, always provide the following details for product identification purposes:

- Model • Mass (kg) • Serial #

This information is engraved on the identification plate located on the wheel chassis.



Figure 1. Identification plate location.

MODEL
MASS
SERIAL #

4-b. Contact Information

Please fill in your machine’s data here for your records:

Micrón Fresar S.R.L.
Rosario de Santa Fe 2256
X2400EFN - San Francisco (Córdoba)
ARGENTINA
TEL.: ++54 3564 498502
E-mail: export@akron.com.ar
www.akron.com.ar

4-c .General comments on Grain Storage in Grain Bags.

The effectiveness of this storage system depends on:

The grain conservation conditions inside the bag.

Work procedure used while bagging the product.

It is the user’s responsibility to study and understand this operations and maintenance manual, paying special attention to all warnings included in each section and to the contents of section 3 “Safety”.

4-d. Operation Principles

The following chart shows the main functions of the machine and the components used to perform each of them.

Function	Related component or system
<i>Grain intake</i>	<i>Receiving hopper</i>
<i>Internal grain movement</i>	<i>Auger driven by tractor PTO</i>
<i>Movement of the bagging machine + tractor together</i>	<i>Automatic movement resulting from grain pressure on the machine’s inclined plane.</i>
<i>Movement speed adjustment</i>	<i>Built-in braking system</i>

PARTS

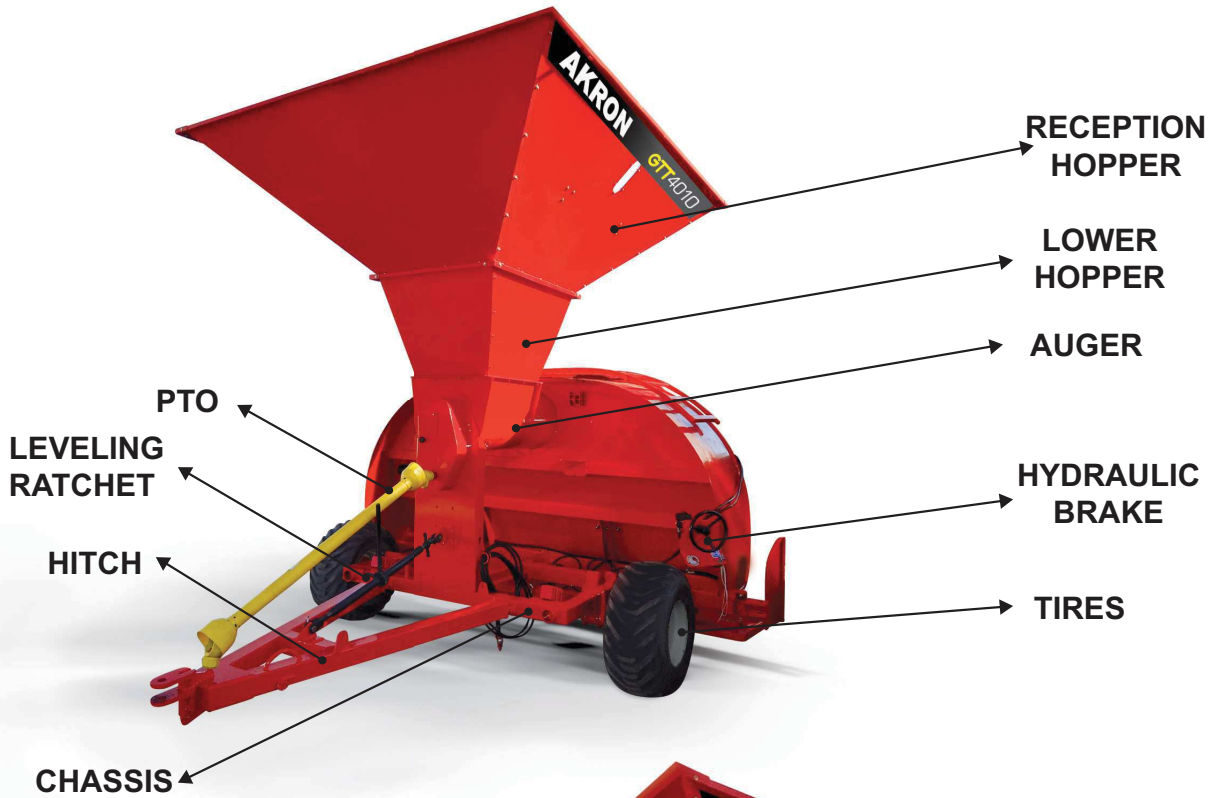

5. PREPARATION AND SETUP

5-a. Recommendations to Ease Subsequent Extraction

The **AKRON®** model EXG 300/EX 3600 grain bag unloaders **AKRON®** are ideal complements to the **AKRON®** model GTT 4010 grain bagger, and they require certain conditions in the situation and preparation of the grain bags.

Figure 1 shows that, if a grain bag is laid parallel to a wire fence, a minimum of 4- meter space must be kept between them, taking into account that the extractor loads a vehicle moving on its right-hand side from the point of view of the tractor driver.

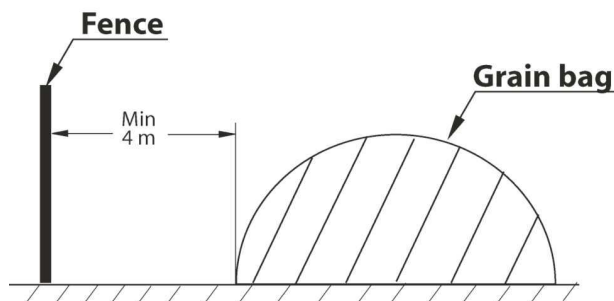

Figure 1- Minimum space between a grain bag and a wire fence

When using the **AKRON EX3600** Grain Bag Unloader to unload the bag, the side distance between bags should be greater than 20 CM (approx 8 inches).

When using the **AKRON EXG300** Grain Bag Unloader to unload the bag, the side distance between bags should be greater than 100 CM (approx 40 inches).

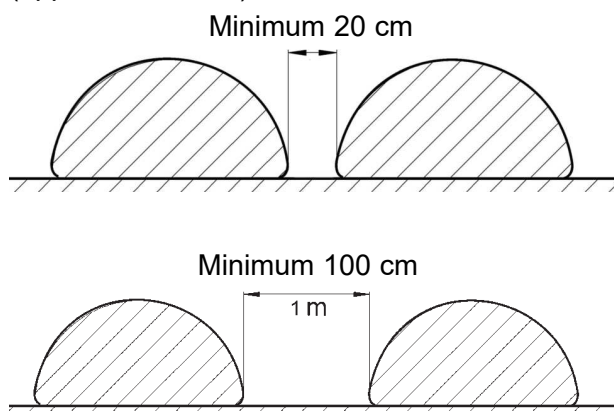

Figure 2 - Space between grain bags

If an **AKRON** unloader is not going to be use to unload the bag, see the operation's manual of the unloader for recommended distance between

en bags.

5-b. Prior Checks on the Machine

It is essential for the machine to be in good state of maintenance as per the recommendations given in section 7 "Maintenance". Nevertheless, the following are some simple checks that should be made prior to starting each grain bag.

- Tire pressure is a very important parameter, since it determines the performance of the machine, which works with permanent braking. The pressure should be between 2.7 and 3.4 bar (40 a 50 lb/pulg²) for adequate operation.
- It is fundamental to visually check that all accessories, locks, means of fixing, etc. are in place and there are no loose, damaged or lost parts. In any of these cases, the necessary adjustments or corrections should be made before operating the machine.
- All protections and safety covers should be checked to be in their place and free from any signs of wear that could hinder their functioning.
- It is advisable to clean all the machine surfaces as thoroughly as possible to make the work safer, since dirty surfaces become more slippery.

5-c. Prior Checks in the Field

The soil must be firm, completely clean and free from remains of seeds, loose earth, weeds, etc., since otherwise the machine's braking conditions could be affected or the grain bag integrity could be at risk. This would logically have a negative effect on the correct conditions for the product's conservation. In the table shown on next page, some precautions are detailed regarding soil condition and its influence on bagging quality.

Preliminary ground preparation and cleaning are extremely important, since they involve little time and low cost but guarantee the integrity of the grain bag and thus greater reliability of the storage system.

5-d. Machine Parking

While parked and uncoupled from the tractor, the machine is designed to remain stable on firm soil with a maximum slope of 8.5°. Uncouple the driveshaft and proceed as explained below depending on the parking direction.

Precautions regarding ground conditions	Importance and related risks
The selected place should be away from trees and forest walls.	It is a good measure to reduce the risk of accidental breakage.
The ground must be free of weeds, stubble, etc.	Imperfections on the ground could damage the bottom part of the grain bag during bagging, which would make it more prone to attacks from rodents.
There should be no loose soil, leftover grain, etc.	The braking capacity of the machine's wheels would be affected and the grain bag would therefore be filled at a tension lower than adequate.
There must be no steep level differences (holes).	If a wheel falls into a hole, the tray could touch the ground, pressing the grain bag against the silo tunnel with the risk of tearing the silo bag.
The ground must be transversally level.	If the machine tilts to one side while operating, grain would accumulate on one side of the grain bag and dangerous tensions would arise on the other side.
The ground must be longitudinally level (in the bagging direction).	The grain bag will "copy" any ground irregularity or imperfection, which can give rise to air spaces that may locally affect product conservation conditions.
On sloping ground, the operating direction must be against the slope.	Bagging must be carried out uphill for the grain bag to be filled in a more controlled and even way.



WARNING: When parking pointing down a slope or against it, the brake must always be applied (50 A 80 kg/cm²), or otherwise the machine will move.

a- Against the slope (Figure 3):



Figure 3 – Bagging machine parked against a slope

Apply the brake to immobilize the machine, install the fixed support leg in the position indicated under the parallelogram and tilt the machine slightly backwards so that said support leg touches the ground. In this position, both tires and the support leg support the machine.

b- Pointing down the slope (Figure 4):



Figure 4 - Bagging machine parked pointing down a slope

Apply the brakes to immobilize the machine. Adjust the angle between the towbar and the chassis by means of the adjustment ratchet until the towbar touches the ground. This will force the machine to tilt backwards until the support leg touches the ground. In this position, both tires, the support leg and the towbar support the machine.

c- Against the slope, machine in oblique position: Proceed as indicated in item a.

d- Pointing down the slope, machine in oblique position: Proceed as indicated in item b.

5-e. Machine Positioning

In order for the machine to remain in a stable position it will be necessary, before uncoupling it from the tractor, to install the support leg found below the Easy Lift, as shown in figure 5. To allow the support leg to touch the ground, it will be necessary to transfer weight from the machine to the support leg. This is achieved by adjusting the angle between the chassis and hitch using the leveling ratchet. After this is done, apply brake pressure to keep the machine stopped.

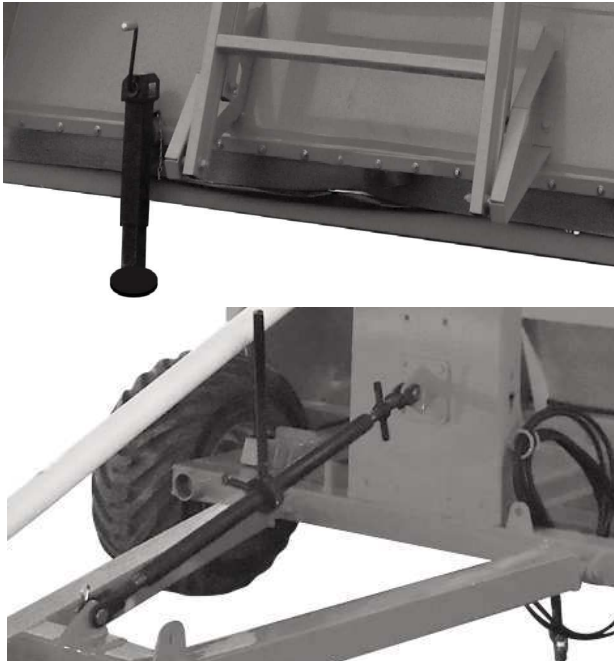

Figure 5 - Support leg rear location from the tractor.

The machine must be coupled to the driving tractor by the towbar, as shown in Figure 6. For safety reasons, the PTO should be connect-only after the grain bag has been mounted on the machine.

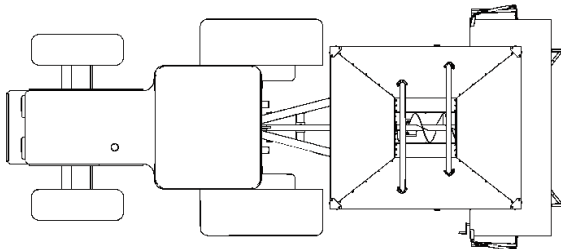

Figure 6 - Bagging machine coupled to the tractor

For mounting the grain bag, the machine must be coupled to the tractor, and the tractor's hand brake should be applied. The machine's brakes should also be applied. The handle operating the hydraulic brake pump can be seen in Figure 7. The braking system initial pressure should be f 40 to 50 bar.



Figure 7 - Hydraulic brake system

5-f Adjusting the brake system.

Follow next steps to properly adjust brake pressure.

PROCEDURE

- 1) Open the safety valve
- 2) Turn the wheel clockwise until desire pressure is reached. Adjust pressure by turning the wheel clockwise or counter clockwise as necessary.

Close the safety valve once the bags manufacturer stretch recommendation is obtained.

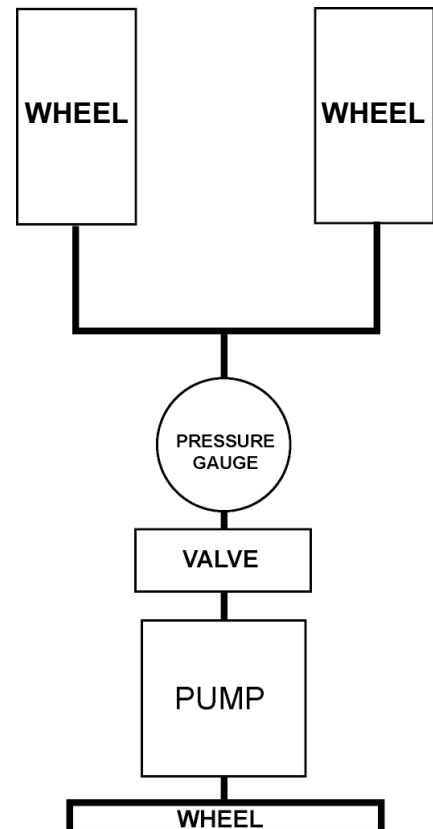

Figure 8 - Functions of the kit valves

5-g. Grain bag Preparation and Mounting

The following are basic instructions for grain bag preparation, but it is essential to observe the particular recommendations of the grain bag manufacturer, since different or additional precautions may be required.

The grain bag must be carefully removed from its package and unfolded on the area where the bagging will be started, which should be clean and level as explained in paragraph 5-b "Prior Checks in the Field".

Then the grain bag can be mounted on the cradle as explained below.

1) Connect the hydraulic hoses to move the pan to its working position. The hydraulic pan has two positions. Extended cylinder: enables to load the bag on top of the pan. Retracted cylinder: normal work and transport position.



Figure 9 – Extended tray

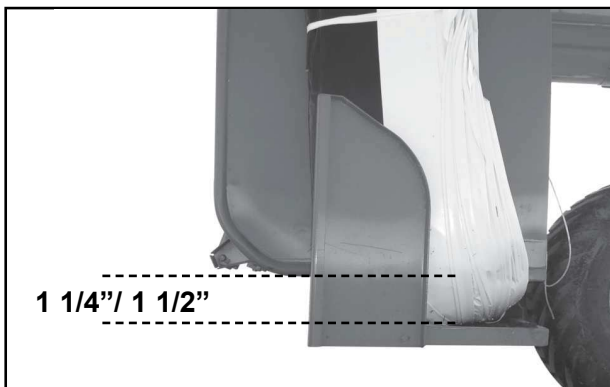

Figure 10 – Retracted tray



WARNING: When the tray is released and lowered, care should be taken not to trap the operator's feet.

2) Remove the latch shown in figure 11 Then, activate the electrical winch to lower the cradle until reaching such a height to comfortably place the grain bag on the lift (70 cm aprox).

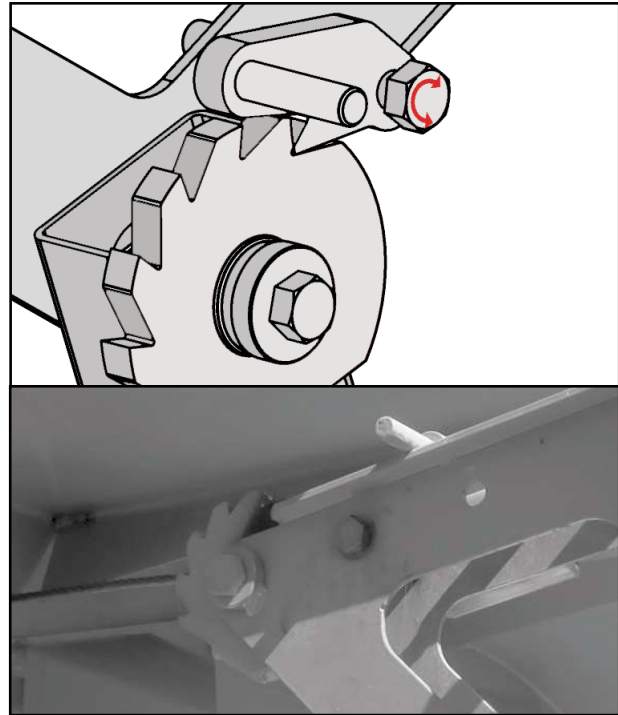

Figure 11 – Cradle fastened by locking lever.



ATTENTION: Never stay on the cradle trajectory while being lifted or lowered. Failure to follow this instruction can cause serious injuries to operator.

3) Use the bag manufacturer middle-of-the-bag mark to center the bag with the cradle. The stretch marks stamped on the bag should always be as shown in fig 12 (15 cm/ 6 inches from the end of the cradle).

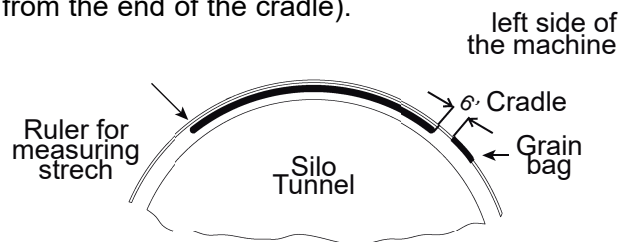

Figure 12- Positioning of the grain bag on the cradle

At the same time the grain bag embraces the tunnel, its bottom part should be supported by the tray. Make sure the grain bag reaches the bottom of the tunnel and all the folds are duly contained in the tray.

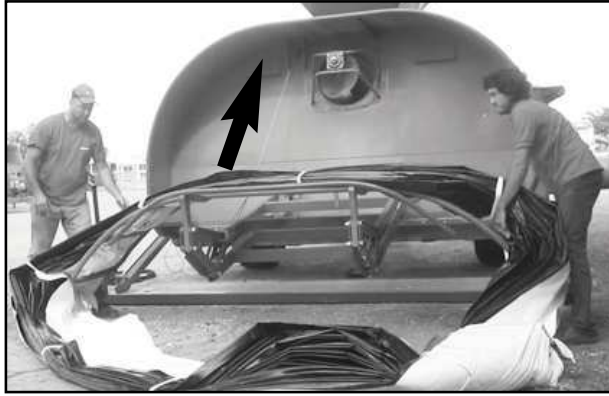

Figure 13 – Cradle down in horizontal position

4) Activate the winch to lift the grain bag. Once the bag is in contact with the machine tunnel, an operator is required to put it into the tray and slide it into the machine sides (figure 14).

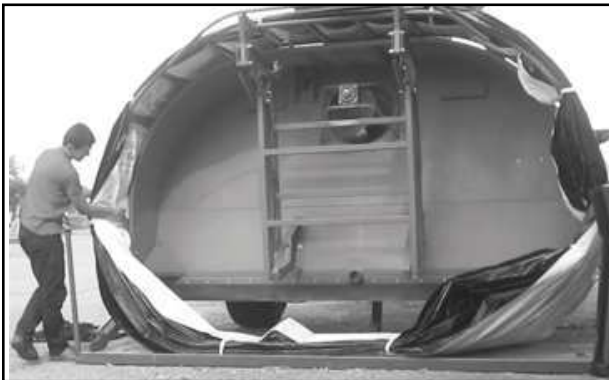

Figure 14 Cradle in its highest position.

5) Once the grain bag has been lifted onto the bagger tunnel, follow the instructions below: Raise the tray until reaching half of its way. Pull the bag from the folds until necessary (6 folds from the tunnel bottom).



Figure 15 Hydraulic tray

6) Put one of the braided elastic ropes through the hole in the tray from top to bottom and tie it to the link in its bottom part.

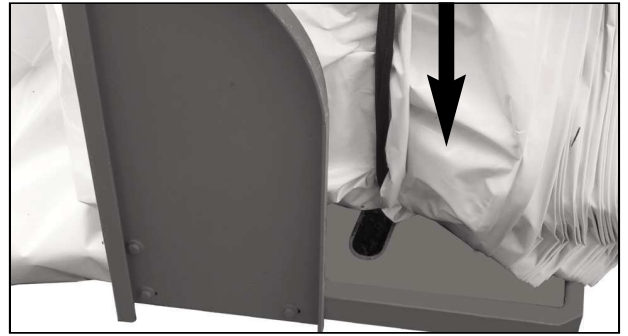

Figure 16. Elastic rope hole

7) Put the rope over the bag across the tunnel and repeat the previous step.
8) Raise the tray into its operating position.

9) Take one of the fixed ropes and follow the instructions below:

- Tie one of its ends to one of the rings in the tunnel front.
- Tie it to the elastic rope.

Then, take it back towards the ring, and tie it to the ring making sure the fixed rope is tightened enough.

-Repeat these steps with the three remaining fixed ropes as shown in figure 17.



Figure 17 - Fixed ropes detail



Figure 18 - Ropes layout.

10) Using the adjustment ratchet, level the machine taking as an approximate reference the upper rim of the grain receiving hopper as shown in Figure 19. If it were necessary to change the turnbuckle rotation direction, turn the lock latch 180°. This way, the correct tray-ground clearance is achieved and the tray is horizontal.

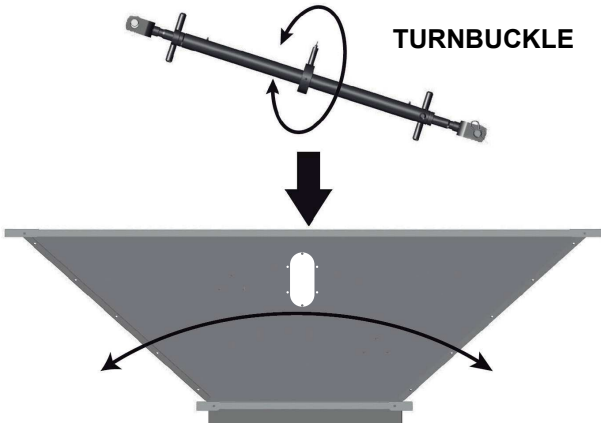

Figure 19 -Bagging machine leveled by means of the turnbuckle.

11) Before continuing with the preparation of the grain bag, check that the auger is completely free from obstructions along the entire tube and sleeve, i.e. that it rotates freely. Figure 20 shows the front of the auger.



Figure 20 -Auger front.

12) Close the end of the grain bag. Although the manufacturer of the grain bag usually gives instructions, paragraph 6-f. "Closing the grain bag" offers general instructions on some of the possible closing methods. Both the closing at the front and at the end of the grain bag are very similar, but the front end must always be rolled downwards and held appropriately while the grain bag starts to fill in order to prevent the end from opening. This is necessary mainly due to the air blowing effect caused by the auger and the grain itself.



Figure 21 - sealing the grain bag

5-h. Final Adjustments Before Starting the Bagging

As indicated before, the machine driveshaft should be coupled to the tractor PTO only after the grain bag has been closed. Otherwise, the operator would be working on preparing the grain bag while the grain conveying auger is accessible and coupled to the PTO, which would involve a risk of being trapped in the case of its accidental operation from the tractor. Keeping in mind that the towbar is already linked to the tractor, proceed as follows:

1) Release the end of the driveshaft from its support on the bagging machine towbar as shown in Figure 22.

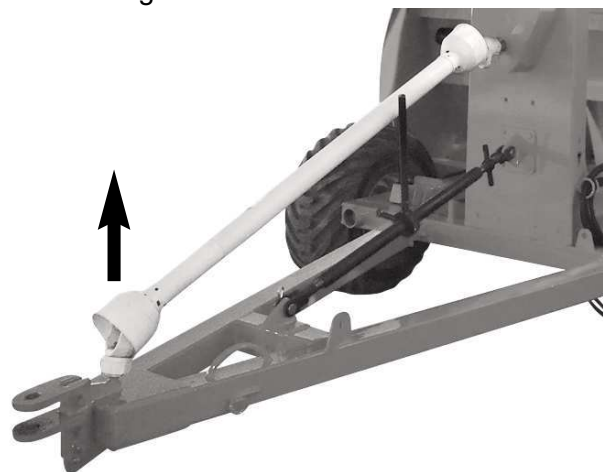

Figure 22- Released driveshaft

2) Extend the driveshaft and couple the splined end to the tractor PTO outlet shaft.

3) Fit the static plastic covers using the chains and locks provided for this purpose. The driveshaft should not be operated without these plastic protectors being properly fixed in place. All the safety warnings indicated on the

driveshaft must also be observed.



WARNING: *Always uncouple the driveshaft if any maintenance tasks must be performed on the machine.*

6. BAGGING PROCEDURE

6-a. Operation Start-up

With the machine and grain bag prepared as explained in the previous section, the bagging operation can be started following these steps:

1) Prepare the vehicle that will supply the grain to be bagged (usually a self-unloading grain cart). This vehicle's discharge tube should be arranged as shown in Figure 1. The grain entering the bagging machine should fall as directly as possible into the centre of the receiving hopper. Otherwise, grain might hit the opposite side of the hopper and spill out.



Figure 1 - Discharge tube position

2) Use a straight line as a reference along the route of the grain bag in order to avoid bends in its entire length. Otherwise, there is a risk of the material being overstretched in some areas, which might make it break later. Some possibilities are: use a distant, clearly-identifiable tree as a reference; lay a string tensed along the route; keep a constant distance from a wire fence.



Figure 2: straight line

3) Remember that both tires should be inflated to

a pressure within the range recommended in paragraph 7. "Maintenance".

4) Check that the initial pressure of the hydraulic brake system is set to 40/50 BAR (550 to 700 PSI). Then, adjust brake pressure until desired bag stretch is achieved, see 6b

5) Gradually operate the tractor PTO until it reaches its running speed, 540 RPM.



IMPORTANT: Always start up the PTO before beginning to introduce grain into the hopper in order to avoid over-loading the auger.



WARNING: When grain enters the receiving hopper and the grain bag end starts to become stressed, the bagging machine and the tractor will suddenly start to move. The operators must be ready for this moment.

6) Start feeding grain gradually, checking that the end of the grain bag is adequately filled and is lying evenly on the ground as shown in Figure 3. Remember that the front end of the grain bag must be turned over.

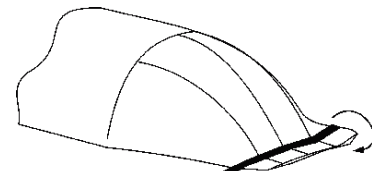

Figure 3 - Filling of the grain bag front end

Stop feeding grain as often as necessary in order to rearrange the end of the grain bag; it will be impossible to correct its position once it is fully loaded.

This initial control is very important so that the stress in the grain bag material is even once storage has been completed. The pressure on the end of the grain bag must not be excessive. Grain must keep its natural slope inside the grain bag end so as not to exert excessive force on the closure.

As the grain enters through the hopper, the auger will convey it to the end of the grain bag until the machine starts moving forward, pushing the tractor. This is a very important moment: the safety of the operators is the priority and care must be taken that, when the machine starts moving, it does not cause any injuries. The movement of the grain feeding vehicle must be coordinated so that grain continues easily entering the receiving hopper of the bagging machine.

6-b. Operation Parameters

1) The machine's braking force is directly related to the resulting tension in the silo bag: the pressure on the brakes should be adjusted (approximately 80 bar) so as to make the best use of the silo bag's storage capacity, i.e. to apply the greatest possible tension to the silo bag material according to the manufacturer's provisions. As shown in Figure 4, most silo bags have some kind of ruler or indication printed on their surface that can be matched with a measurement template supplied by the manufacturer in order to determine the degree of tension on the plastic material.

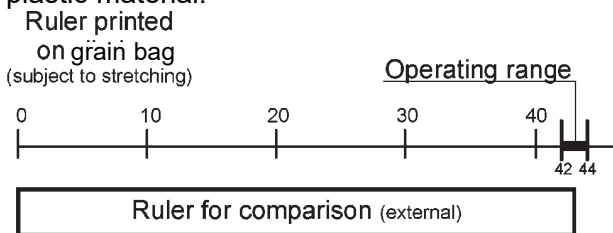

Figure 4 – Ruler printed on the silo bag

It is safer to stay in the centre of the grain bag's stretching range so as to allow for further grain settling.

2) Apart from checking this on the grain bag, it is most important not to exceed 150 bar (1500 kPa) in the hydraulic brake system. The manometer has an indication of the operating pressure range.

3) If, despite the precautions explained in 5-b "Prior Checks in the Field", the bagging machine wheels skid due to wet ground or loose soil, the pressure of the hydraulic brake circuit must be reduced. As a last resort, if this is not enough, the tractor's brake can be used to contribute to braking both machines, but the purpose of the bagging machine wheels is to rotate, not to skid.

4) Make sure the grain bag is unfolded gradually, one fold at a time.



Figure 5 - Grain bag folds

6-c. Protection against Overloads

In the machine's driveshaft intake there are mechanical fuses, consisting of screws that will break if there is any overload in the transmission.

These screws should never be modified under any circumstances, since they guarantee the machine's integrity and its correct operation. In order to reestablish transmission, replace the broken screw using the indications given in the following table:

Walterscheid driveshaft

Size	Grade	Type	Surface protection	Quantity
M8X1.25X60	8.8 DIN -ISO 931-960	Hexagonal head	Zinc- or cadmium-plated	1

Bondioli & Pavesi driveshaft

Size	Grade	Type	Surface protection	Quantity
M10x1.5x50	8.8 DIN -ISO 931-960	Hexagonal head	Zinc- or cadmium-plated	1

Micrón Fresar driveshaft

Size	Grade	Type	Surface protection	Quantity
M8x1.25x50	8.8 DIN -ISO 931-960	Hexagonal head	Zinc- or cadmium-plated	1

If these screws break repeatedly, the causes provoking this should be investigated.

6-d. Interruptions during Bagging

If the bagging operation has to be temporarily interrupted, this procedure will have to be followed:

1) Stop feeding grain into the receiving hopper of the bagging machine. The auger should be left rotating in order to remove all the grain left inside the receiving hopper and the conveying tube.



IMPORTANT: Remember that the receiving hopper drives the cereal toward the auger. Do not use it for storage purposes.

2) Wait for a moment until the auger conveys all the remaining grain from the receiving hopper to the grain bag. The tractor and bagging machine will stop moving almost as soon as the hopper and the conveying tunnel are emptied. Operators should be ready for this sudden

stopping of the machine and the linked tractor.

3) By this time, the auger will be rotating unloaded. Gradually, reduce PTO speed until it stops, when the auger will also stop rotating.

 **IMPORTANT:** *The auger should be completely free of grain when it is stopped, since any grain left there would produce an excessive load on the auger when it is started again.*

4) Apply the tractor's hand brake as well, to make sure to prevent any grain bagger and tractor additional unexpected movement

5) If any maintenance, repair or inspection tasks need to be carried out on the machine, uncouple the driveshaft from the tractor PTO and prop it on the towbar end support as shown in the figure 6.



Figure 6 - Driveshaft propped on towbar end

6) If the tractor must temporarily leave the bagging site, release the towbar adjustment ratchet until the tractor hitch pin can be removed.

 **WARNING:** *If the machine is left attached to a semi-prepared grain bag and the driving tractor is removed, care should be taken that the pressure of the hydraulic brake system does not fall. It is best to place wedges on both sides of the machine wheels in order to avoid unexpected movements.*

6-e. Operation at the End of the Grain Bag

Most grain bags have some kind of indication printed on their surface, e.g. a colored stripe, to show that the bottom end is being reached. When this kind of indication appears, or when there are about 4 (four) grain bag folds left on

the silo tunnel, proceed as follows:

1) Follow instructions 1, 2 & 3 from the previous paragraph, 6-d "Interruptions during Bagging".
2) Apply the tractor's hand brake.



WARNING: *If the tractor's hand brake is not in a good condition, when the bagging machine brakes are released grain pressure might push the bagging machine and its linked tractor and the operators would not be able to control it. It is best to stop the tractor engine and leave it in a low gear.*

3) Once the bagging machine is properly held by the tractor, release its own built-in brakes.

4) Gradually release the tractor's hand brake and use a low gear at the same time if necessary. In this way, the pressure exerted by the remaining cereal will push the bagging machine-tractor assembly forward an additional distance.

5) Tow the bagging machine using the tractor until the portion of the grain bag left on the machine's silo tunnel is finally released. The bottom end of the silo bag will then be completely free to be closed.

6-f. Closing the Grain Bag

Both the front end of the grain bag and its bottom end can be closed using different systems (see paragraph 5-g "Grain Bag Preparation and Mounting"). Instructions for these can usually be obtained from the silo bag manufacturers.

In general terms, the following grain bag closing methods can be explained.

Plastic Closure

This consists of a strip split in two halves, male and female, which trap both sides of a grain bag. This is a high-quality and quick closing method. This operation requires a special hand tool to lock the plastic seal. Proceed as shown below:



Insert the end of the grain bag into the "U" channel (female half of the plastic closure).

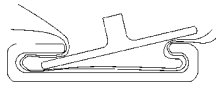

Mould the grain bag material until it fits into the "U" shape and locate the male half of the plastic seal.

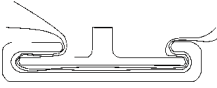

Place the special tool with its roller in the centre of the seal and press on the male half until it is inserted into the female half.

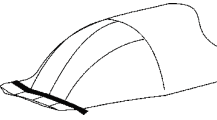

To close the seal completely, the roller must be run from one end of the width of the silo bag to the other.

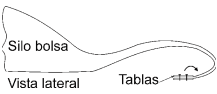

Rotate the plastic closure 2 or 3 times, also winding the grain bag.

Wooden Boards

This is an economical solution, in which the materials to be used must be prepared adequately to prevent a precarious closing from causing an inadequate sealing. Do the following:

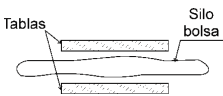

Arrange two wooden boards on the end of the silo bag to be closed.

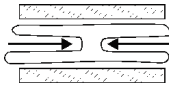

Laterally fold the silo bag, reducing its width so that the boards cover all the material.

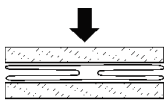

Join both boards checking that the entire silo bag width is pressed between them.

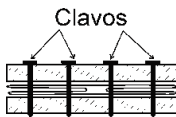

Nail the boards to each other.

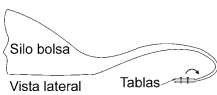

Rotate the board assembly 2 or 3 times, also winding the silo bag.

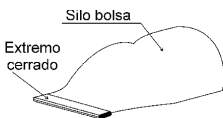

The sealing must have a compact look.

Rope

This is a simple and economical method but it involves a loss of length, since the silo bag must be folded and turned over. The success of this

method depends on the operator's skill. Do the following:

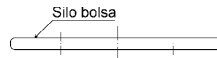

Visually divide the width of the end of the grain bag into 4 (four) parts.

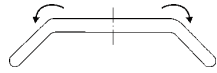

Fold the outside two fourths downwards.



The grain bag end width will thus be reduced.

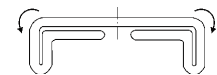

Continue folding the sides of the end downwards.

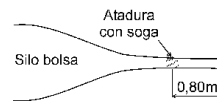

Tie the "roll" thus obtained with a rope located some 0.80 m (2.5') from the end of the grain bag.

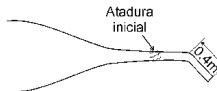

Fold about 0.40 m (1.25') of this "roll" downwards.

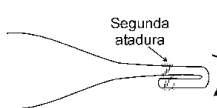

Make a second tie with the rope at the same height as the initial tie.



If you are working on the initial end, fold the tie so that it is left under the grain as the grain bag starts to fill.

When you are closing the initial end of the grain bag, it must be held down properly with some weight while it starts filling. This is necessary due to the air blowing effect produced by the auger, even before the grain enters the receiving hopper.

7. MAINTENANCE

The machine is simple, so the only maintenance tasks necessary are the following.

7-a. Maintenance Schedule

The following tables show the maintenance tasks that have to be carried out periodically.

All the tasks indicated as “daily” should be carried out before starting every workday, and the ones indicated as “weekly” should also be carried out when there is any significant change in the conditions of work (change of silo bag, change of grain).

It is very important to keep a written record of all the maintenance tasks performed on the machine.

Daily Tasks

Condition to check	Normal situation	Correction method
General machine condition	Free movements in general, reasonable cleanliness of main components	Eliminate causes of possible restrictions on the movements; remove any dirt that could hinder the machine's operation.
Condition of the conveying auger tube	Free from obstructions or excessive dirt	Eliminate possible obstructions or dirt left inside the tube.

Weekly Tasks

Condition to check	Normal situation	Correction method
Tire pressure	Between 2,7 and 3,4 bar (40 and 50 lb/pulg ²), both tires at the same pressure	Adjust tire pressure

Half-yearly Tasks

Condition to check	Normal situation	Correction method
Tightening torque for the clamps holding the lifting cable to the parallelogram assembly.	Clamp nuts tightened	Tighten the nuts, torque 2 kgm (20 Nm)
Condition of the hoist steel cable	Not more than 3 wires cut on a single strand. Not more than 6 wires cut on all the strands along an entire pitch.	Replace the cable as indicated in paragraph 7-d, under the title “Hoist Cable Replacement”.
Operation of auger support bearings	Silent rolling, free from bumps or abnormal vibrations	Grease the bearings using the grease fittings supplied for this purpose. Use NLGI grade 2 lithium grease. If the problem is not solved, dismantle and evaluate possible replacement according to the instructions given in paragraph 7-d., under the title “Auger Support Bearing Replacement”.

7-b. Maintenance after Receiving the Machine

After some 30 hours of continuous operation, it is essential to re-tighten all the machine's screws using the following torque values recommended for SAE grade 5 zinc-plated screws:

Size	Torque [kgm - N.m	(ft.lb)
1/ 4" - 20	0,96 - 9,5	(7,03)
5/16" - 18	2,03 - 20	(14,81)
3/ 8" - 16	3,61 - 35,5	(26,29)
7/16" - 14	5,81 - 57	(42,22)
1/ 2" - 13	8,86 - 87	(64,44)
9/16" - 12	12,74 - 125	(92,59)
5/ 8" - 11	17,58 - 172	(127,77)
3/ 4" - 10	31,29 - 307	(227,40)

Chain tension:

Adjust the chain until the free strand can move freely 3/8" to 5/8" (10 to 15 milimeters) using light hand force.

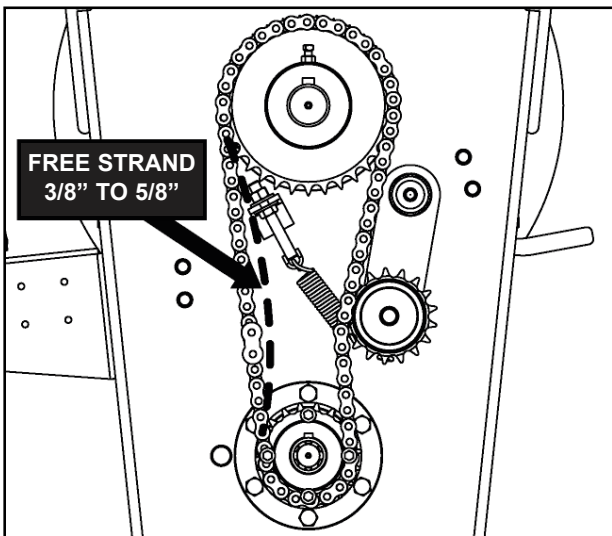

Figure 1 - Proper chain tension

7-c. Lubrication

NLGI grade 2 lithium (multiple-purpose automotive) grease is recommended for all the lubrication points

7-d. Replacement of Parts Subject to Wear

Hoist Cable Replacement

1) Operate the winch until the cradle reaches the ground. (cable should have no tension)

2) Remove the cable holders on each end of the cable.

3) Remove the old cable and place the new one. This new cable should have the same characteristics as the one used by the manufacturer.

4) Lift and lower the cradle system several times to check for proper cable installation

Auger Support Bearing Replacement

1) Identify the UC 209 bearing and release the Allen studs that fix it to the rear shaft end.

2) Remove the hex head screws (1/2") from the support to remove it. Care must be taken to prevent the auger from falling suddenly on the support.

3) Insert the UC 209 bearing on the rear shaft end. Then, position the support and tighten the hex head screws (1/2") on the rear support.

4) Tighten the Allen studs that fix the bearing.

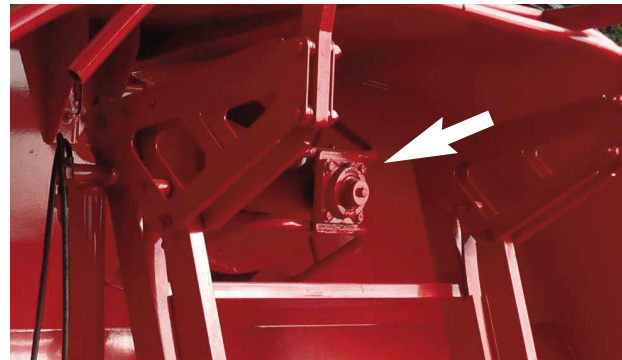

Figure 2 - Bearing Replacement

7-e. Brake Fluid

Brake fluid level should regularly be checked. The tank should be at half point approximately. Brake fluid should be Type 3.

7-f. Wear Prevention on Flexible Pipes

Take into account the following items for a better use and take care of the flexible pipes included in the machine.

- Visually inspect each one of the brake hydraulic circuit components and hoses. They should not have leakages: Keep them from touching sharp objects. Do not tread on hoses

and keep them from being strangled.

- Be careful when working with brake liquid, since it can cause burns on your skin and wearing on metal parts.
- Check the helical cover on the hydraulic circuit is in good condition in order to prevent the operator from being splattered with fluid



Figure 3 - Prevention on Flexible Pipes

7-g. Tire Change

Follow the below steps:

- 1) Slightly loosen the wheel nuts.
- 2) Lift the machine using a mechanical or hydraulic jack applied to the chassis in the location indicated by the decal, as shown in Figure 4.



Figure 4 - Support point for jack location

3) Once the bagging machine has been lifted, install the assembled wheel and the five wheel nuts .

4) Tighten the wheel nuts using a 21 mm hexagonal wrench up to a final tightening torque of 9 kgm = 90 Nm = 65 ft lbs. pie.



IMPORTANT: *Remember to re-tighten wheel nuts during the first 3 weeks for them to fit better on the wheel rims.*

8. MACHINE TRANSPORTATION AND STORAGE

8-a. Preparation of the Machine for Transport

Once the grain bag has been released from the bagging machine, prepare the machine for transportation in the following way:

- 1) Uncouple the driveshaft from the tractor PTO and put it on the towbar support.
- 2) If not been done yet, lift the cradle and put the latch.
- 3) Make sure the pan has reached its highest position using the hydraulic cylinder.
- 4) Check both brakes are completely released, i.e. there must be no pressure in the hydraulic system.
- 5) Adjust the angle of the machine by means of the adjusting ratchet if necessary.
- 6) Make sure the support leg is back to its transport/work position once the machine is coupled to the tractor.

8-b. Transportation

The bagging machine requires no special configuration changes apart from the ones explained in paragraph 8-a. "Preparation of the Machine for Transportation". Figure 1 shows the machine ready for transport and also indicates the towbar hitch. The maximum force that should be exerted on the tractor hitch pin is 650 N. Brake hydraulic circuit should remain with no pressure.

IMPORTANT: *The GTT 4010 grain bagger is not designed for road travel. Therefore, MICRON FRESAR S.R.L. accepts no liability for accidents or damage that may be caused during transport if the machine is made to travel on roads.*



If the user still needs to do this, we recommend consulting national, provincial and municipal safety regulations in force in each region.



Figure 1 – Bagging machine ready for transport

8-c. Machine Storage

Before storing the bagging machine, ensure that the brake hydraulic system is left without pressure. If the machine is expected to be stored for several days, it is important to adequately grease all the moving parts.

The machine must be stored indoors in a clean and dry place, preferably with a cover to protect it from dirt. If the bagging machine is to stay outdoors temporarily, the lower auger cover should be left open.

9. SPECIFICATIONS

DIMENSIONES

9-a. List of Main Components

32000 bu/hr capacity (bagger only).

Tare:
1900 kg

Tunnel: For grain bags up to 10 feet.

Operation: 80 HP tractor equipped with a 540 rpm PTO.

Tube / auger: 20".

Braking system: Hydraulic, with built-in manual pump.

Towbar height adjustment: Enough to absorb differences in the hitch.

Transport position: No wheel configuration changes are required.

The loading capacity of the machine is based on standard grain moisture (wheat at 13% moisture content). Bagging speed should be slowed down when bagging grain at 17% moisture or higher, otherwise the higher demand of horse power can break the PTO overload shear pin. The PTO must always run at 540 rpm.

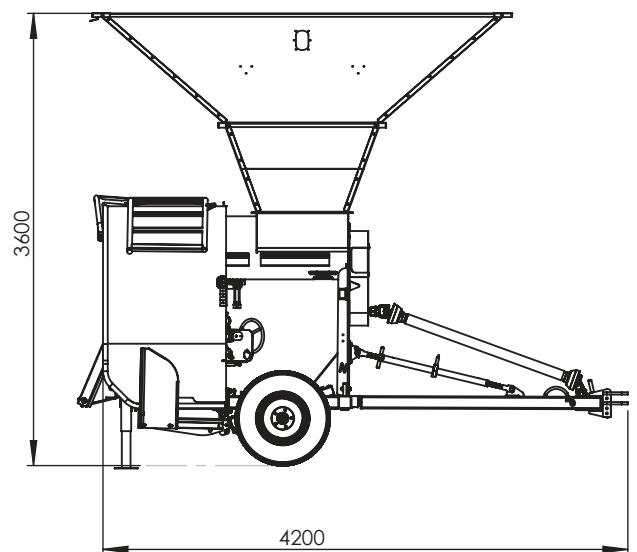
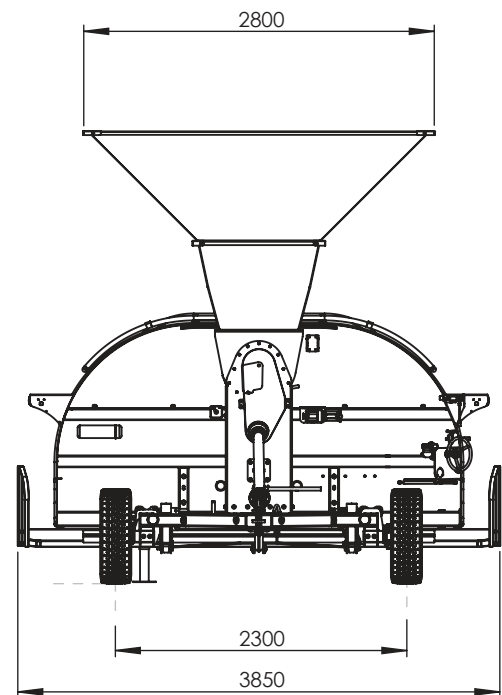

10. PRODUCT DISMANTLING AND DISPOSAL

The following is meant to inform the user about the steps to follow when the lifespan of the machine, of its fluids or components comes to an end. Dismantling and disposal instructions are included.

- Metal parts or assemblies replaced or modified for particular reasons such as corrosion or wear should be properly disposed of. They should be sent to scrap storehouses or foundries where they can receive an adequate treatment. It is essential to wear personal protective equipment (safety gloves) when handling sheet steel.
- The system fluids which are periodically replaced (non-biodegradable hydrocarbon-derived oils and greases) should not be disposed of in the soil or in water courses, since this would result in environmental pollution. Up to now, the most usual application for these wastes is to use them as fuel for vapor generators (boilers) burning fuel-oil. They may also be burnt in special waste-burning kilns. Otherwise, they should be delivered to companies authorized to handle and transport them.
- Some practical use may be found for tires when they are removed from the machine after becoming worn out. Otherwise, they should be taken to a tire-recycling centre for their medium- or long-term integration into the ecological cycle according to national, provincial and municipal regulations in force.

11. GUARANTEE TERMS

Micrón Fresar S.R.L guarantees the **AKRON® GTT 4010** grain bagging machine for a one-year period since the date in which the new unit is delivered to the customer. This guarantee covers defects in materials used to manufacture the machine, provided that the grain bag unloader has been properly operated. The operating procedures considered appropriate are those described in this manual.

This guarantee does not cover the following:

Damages or failures as a result of improper operation or lack of machine maintenance that may occur during transport, operation, or parking from the delivery date.

Tires own guarantee.

Normal wear of parts due to their use. Their replacement is part of the preventive maintenance.

Micrón Fresar S.R.L is not responsible for any repair made by third parties, or damages resulting from this cause.

Micrón Fresar S.R.L, reserves the right to modify the guarantee terms without previous notice.

Micrón Fresar S.R.L. reserves the right to modify specifications and designs without previous notice and without the obligation to implement these changes in the machines already delivered.

Damages caused during machine operation by any person whose abilities are affected or reduced will not be covered.

If the machine is sold by the first owner within the guarantee term validity, this will be transferred to the new owner, provided that **Micrón Fresar S.R.L** is advised by written notice. Such guarantee will not be valid if the current owner of the machine (not being the original buyer of the product) has not advised **Micrón Fresar S.R.L** in due time.

The guarantee will automatically become invalid if any of the parts of the machine is modified or replaced by spare parts not provided by **Micrón Fresar S.R.L**. If such replacement or structural modification was urgently necessary, the user must obtain written approval from **Micrón Fresar S. R. L.** to make such changes without

affecting these guarantee terms.

In order for the guarantee to come into force, it is an essential condition to submit a request for guarantee repair together with the following information:

Name:

Date in which the damage occurred:

City:

Phone Number:

Machine Model:

Serial Number:

Invoice Number:

12. SPARE PARTS LIST

All the components of the **AKRON GTT 4010** grain bagger are detailed in the following pages. To order a spare part for your machine, do the following:

- Use the attached exploded diagrams, from identify the component/s to be replaced.
- Note the code of each part and, if possible, the name of each assembly.
- Order the spare parts from your nearest **AKRON®** Technical Representative or to **AKRON®** Spare Parts Service (see 12-a “Information to Obtain Spare Parts”), indicating each part’s code and, if possible, the name of each assembly.
- If replacing a part that originally included safety decals, check that these are also present on the replacement part.

12-a. Information for Obtaining Spare Parts

AKRON® Spare Parts Service
Micrón Fresar S.R.L.
Rosario de Santa Fe 2256
X2400EFN - San Francisco (Córdoba)
ARGENTINA
Tel: +54 3564 498502
E-mail: export@akron.com.ar
www.akron.com.ar

The nearest **AKRON®** Technical Representative can also be contacted to obtain machine components.

ASSEMBLY STEP # 1 / CHASSIS AND TUNNEL

#	PART#	DESCRIPTION	QTY.
1	29.29.33200	CHASSIS AND TUNNEL	1
2	29.39.33101	WHEEL CHASSIS	1
3	98.304.111158	HEX NUT, G5 5/8" BSW	12
4	29.39.25168	HUB WITH DISC BRAKE	2
5	98.309.101158	FLAT WASHER, 5/8"	12
6	98.002.158051	HEX HEAD SCREW, 5/8" X 2" BSW	12
7	29.39.28915	LEFT LIGHT SUPPORT ASSEMBLY	1
8	29.39.28916	RIGHT LIGHT SUPPORT ASSEMBLY	1

ASSEMBLY STEP # 1 / CHASSIS AND TUNNEL

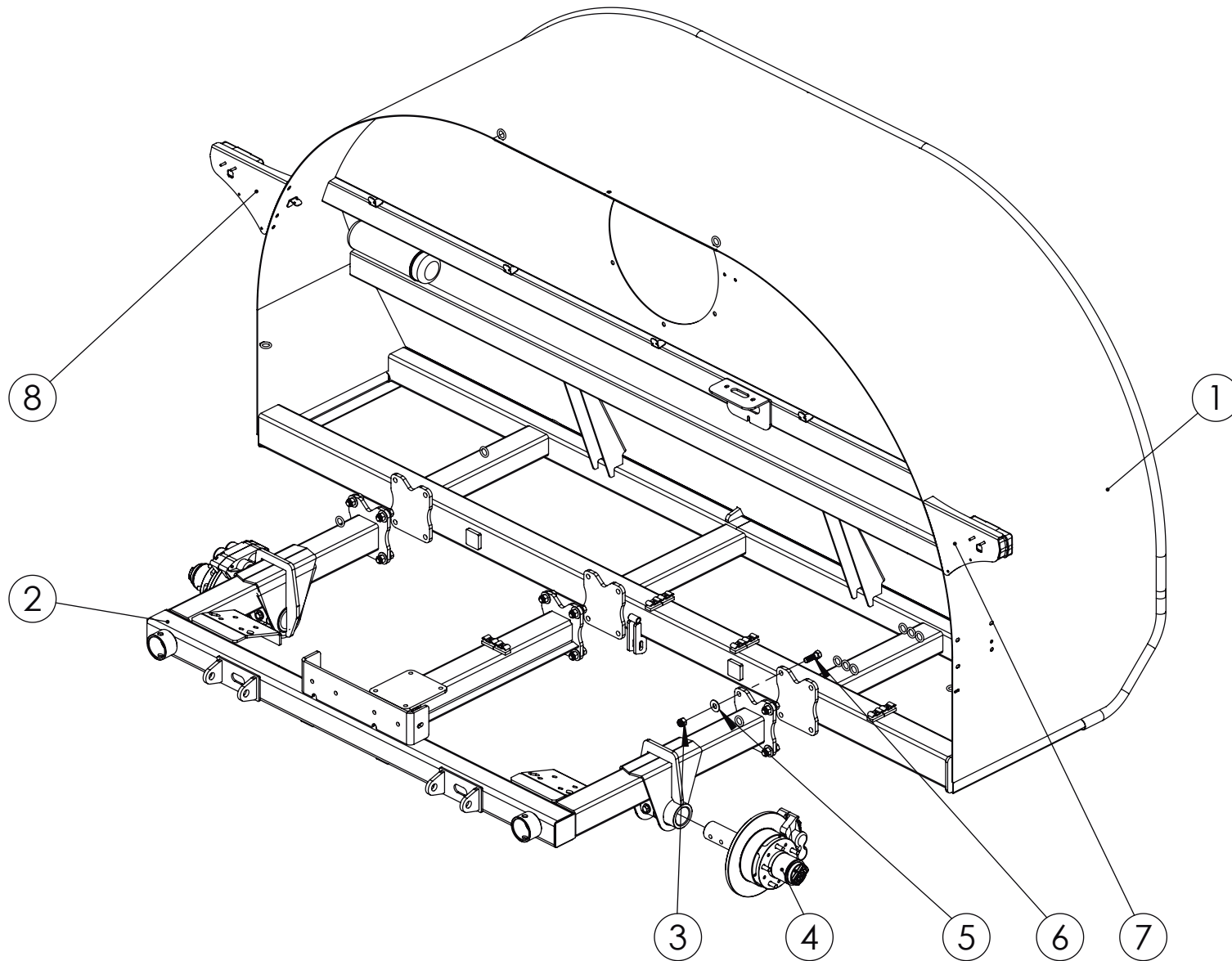

ASSEMBLY STEP # 2 / COLUMN / TUBE

#	PART#	DESCRIPTION	QTY
1	29.42.33443	CHAIN INSPECTION COVER	1
2	29.39.33440	FRONT COVER	1
3	29.39.33385	COLUMN TUBE ASSEMBLY, Ø500MM	1
4	29.39.33380	TUBE ASSEMBLY, Ø500MM	1
5	29.39.30380	AUGER BEARING HOUSING WITH SPROCKET	1
6	29.39.30730	ROLLER CHAIN TENSION SYSTEM	1
7	98.304.150127	LOCK NUT, G5 1/2" RW	6
8	29.39.30400	SUPPORT BOX WITH INLET SHAFT	1
9	29.39.33360	ROLLER CHAIN ASA 80-2 1"	1
10	98.342.025725	SPRING	1
11	25.43.25726	TENSION REGULATOR	1
12	98.408.014264	WHEEL KNOB, LTD 875 1833	1
13	98.002.063019	HEX HEAD SCREW, G5 1/4" X 3/4" BSW	1
14	98.309.100063	ZINC PLATED FLAT WASHER, 1/4"	1
15	98.304.151063	LOCK NUT G5 1/4" BSW	1
16	98.002.127044	HEX HEAD SCREW, G5 1/2 X1 3/4" BSW	14
17	98.309.101127	ZINC PLATED FLAT WASHER, 1/2"	6
18	98.301.150127	HEX. NUT. G5 1/2" BSW	14
19	98.310.100127	LOCK WASHER, 1/2"	20
20	98.309.101095	ZINC PLATED FLAT WASHER, 3/8"	9
21	98.304.151095	LOCK NUT G5, 3/8" BSW	9
22	98.002.127038	HEX HEAD SCREW, G5 1/2 X 1 1/2" BSW	6
23	98.002.079025	HEX HEAD SCREW, G5 5/16" X 1" BSW	4
24	98.309.101079	ZINC PLATED FLAT, 5/16"	4
25	98.301.150079	HEX. NUT. G5 5/16" BSW	4
26	29.39.33350	AUGER	1
27	98.002.095025	HEX HEAD SCREW, G5 3/8" x 1" RW	16

ASSEMBLY STEP # 2 / COLUMN / TUBE

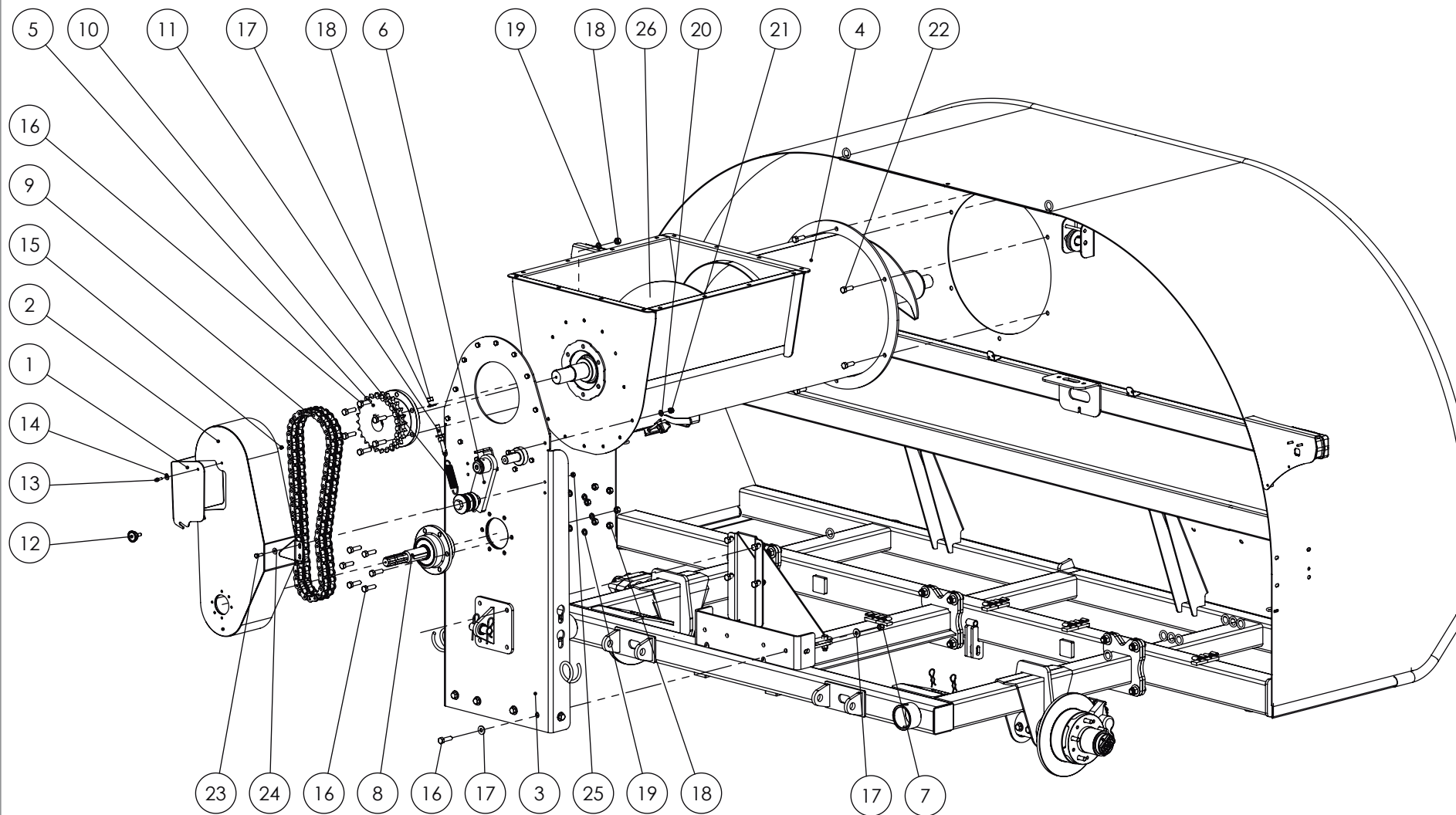

ASSEMBLY STEP # 2 / COLUMN / TUBE

#	PART#	DESCRIPTION	QTY
1	98.002.127038	HEX HEAD SCREW, G5 1/2" X 1 1/2"BSW	6
2	98.002.127044	HEX HEAD SCREW, G5 1/2" X 1 3/4" BSW	4
3	98.310.100127	LOCK WASHER, 1/2"	11
4	27.43.80417	END BUSHING STOP WASHER	1
5	98.755.355545	UC 209 BEARING	1
6	06.41.00145	AM 45 SUPPORT WITH BEARING	1
7	29.42.27366	AM 45 SUPPORT PROTECTION COVER	1
8	29.39.27360	AM-45 SUPPORT ASSEMBLY	1
9	98.301.150127	HEX NUT. G5 1/2" BSW	10

ASSEMBLY STEP # 2 / COLUMN / TUBE

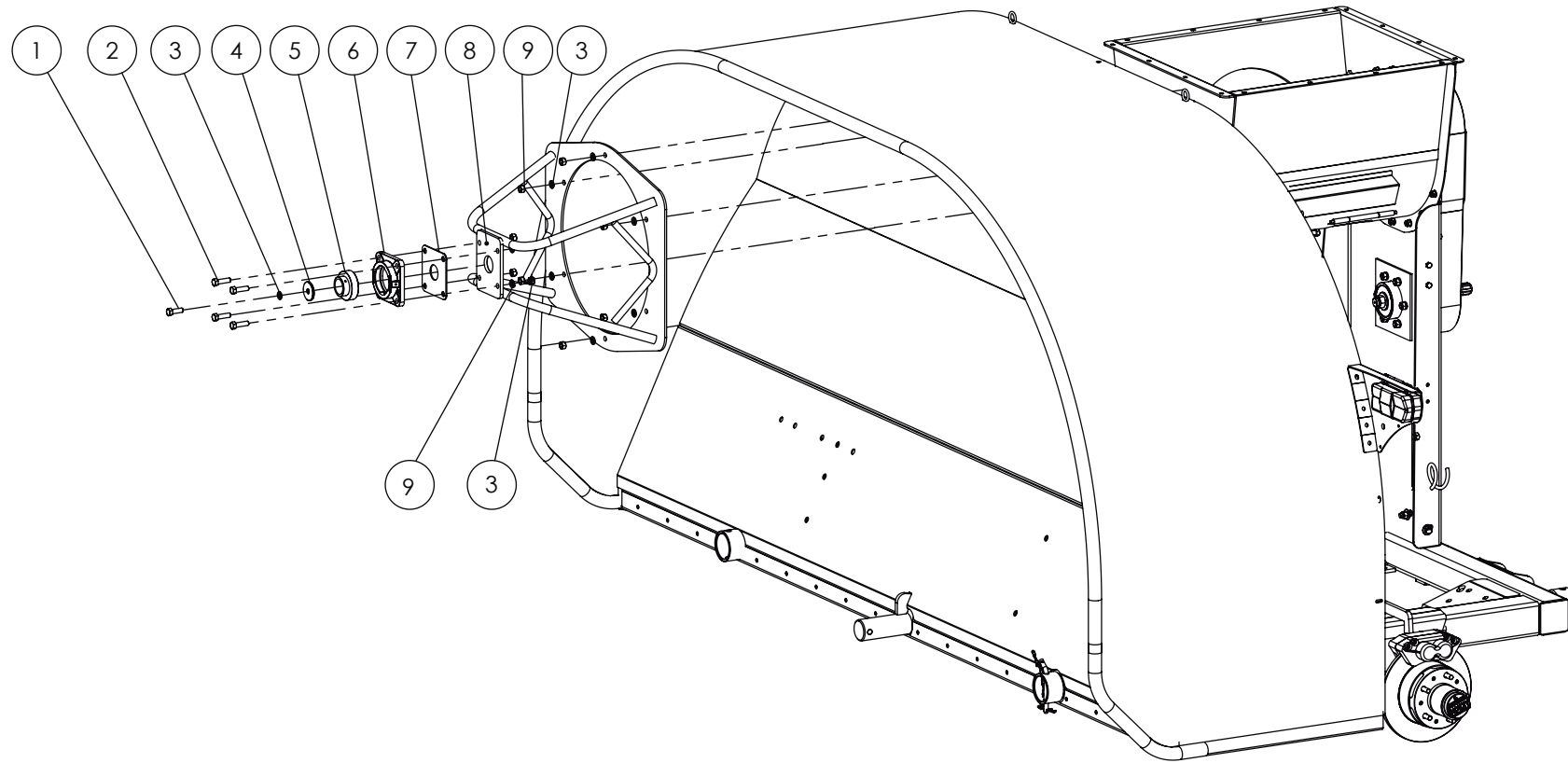

ASSEMBLY STEP # 2 / COLUMN / TUBE

#	PART#	DESCRIPTION	QTY
1	98.002.127044	HEX HEAD SCREW G5, 1/2X1 3/4" BSW	14
2	98.304.151127	HEX. NUT. G5 1/2" BSW	14
3	98.309.101127	FLAT WASHER, 1/2"	20
4	29.39.26340	ADJUSTMENT RATCHET SUPPORT	1
5	29.39.26135	ANGLE BRACKET & BASE	1

ASSEMBLY STEP # 2 / COLUMN / TUBE

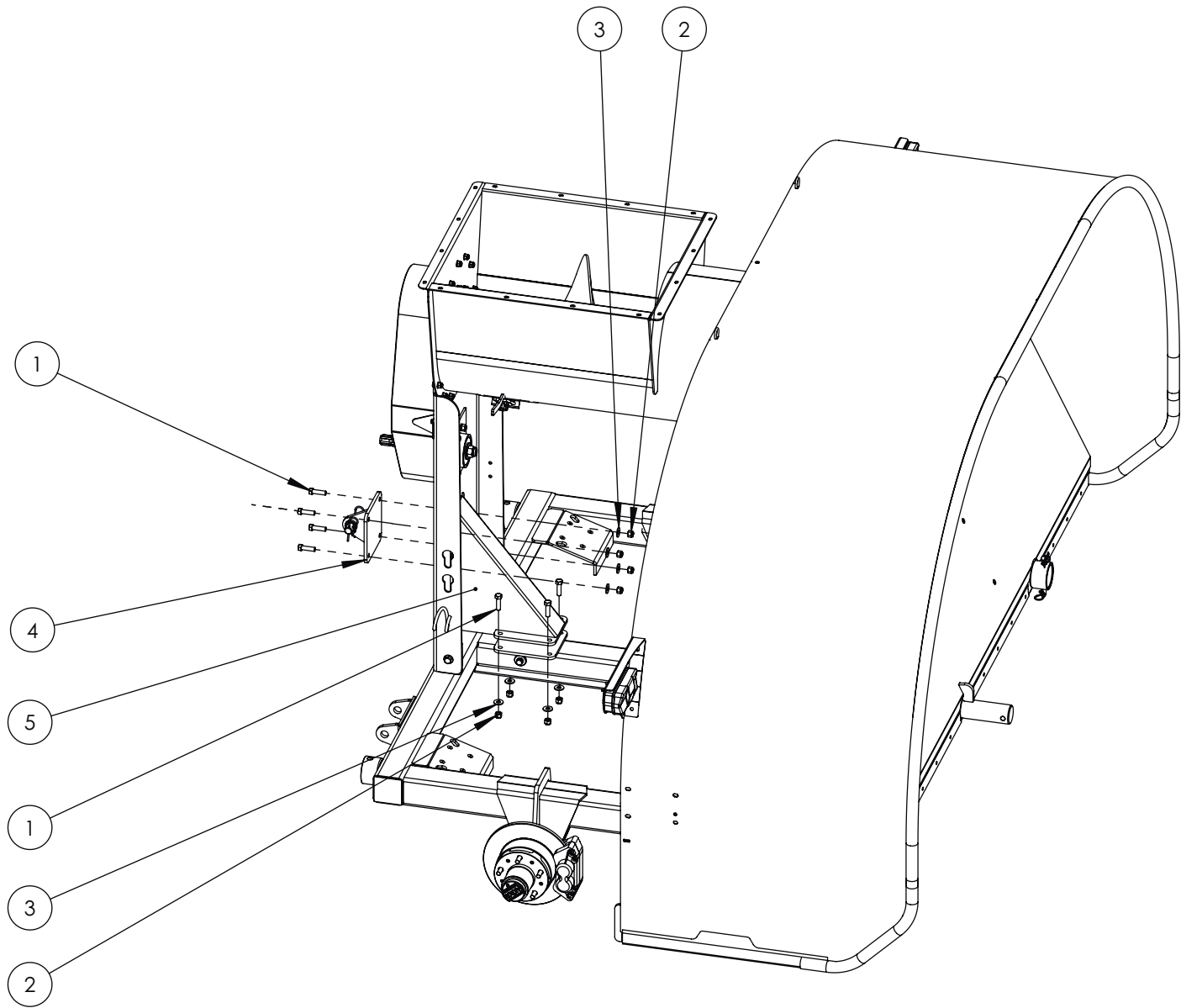

ASSEMBLY STEP # 3 / LOWER HOPPER

#	PART#	DESCRIPTION	QTY.
1	29.42.33448	HOPPER ANTI-SPILL BRACE	4
2	29.42.33446	FRONT PLATE - LOWER HOPPER REAR SHEET	2
3	29.42.33447	BOTTOM HOPPER SIDE PANEL	2
4	98.002.079025	HEX HEAD SCREW, G5 5/16" X 1" BSW	34
5	98.304.151079	LOCK NUT, G5 5/16" BSW	34
6	98.309.100079	ZINC PLATED FLAT, 5/16"	68

ASSEMBLY STEP # 3 / LOWER HOPPER

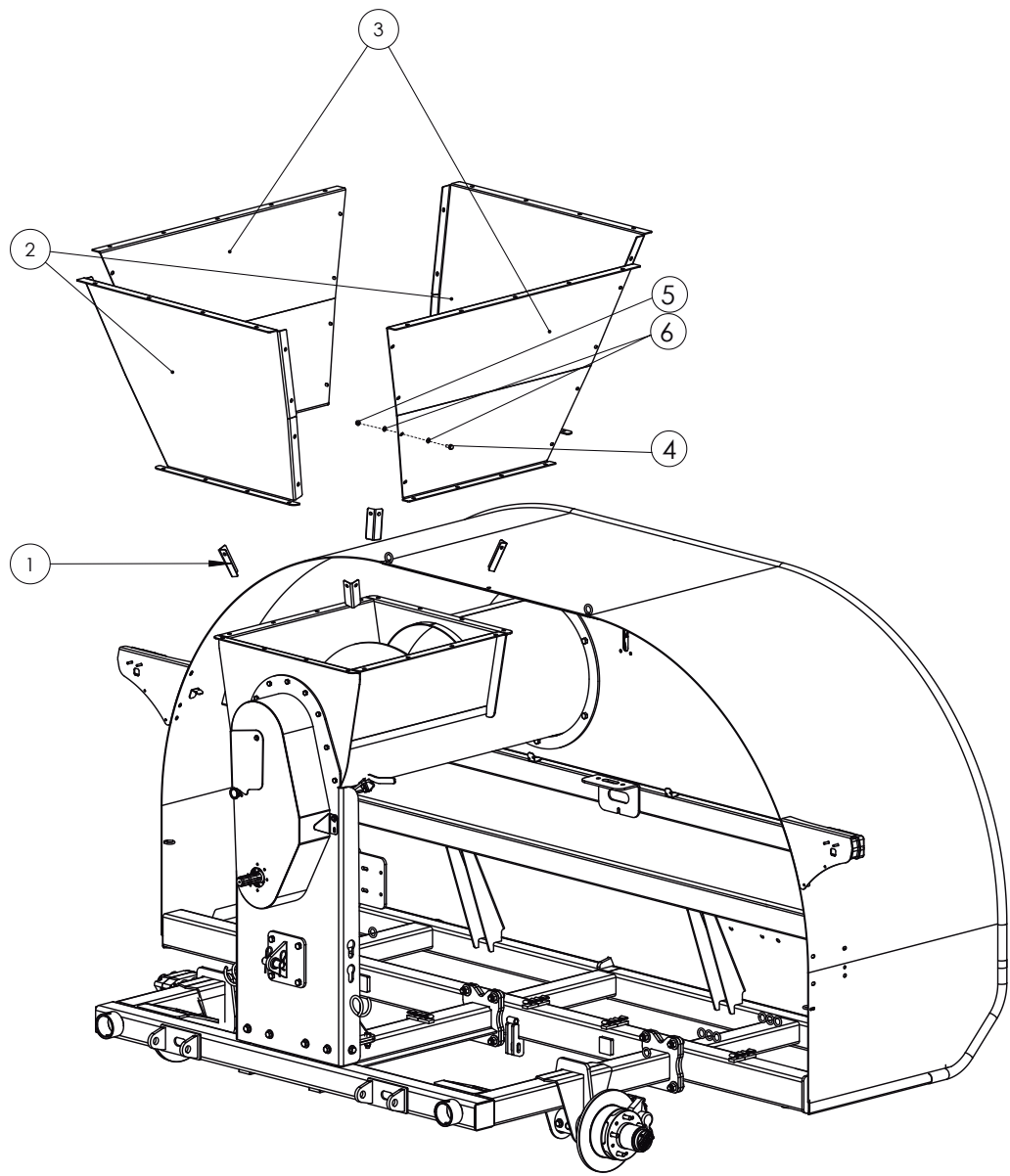

ASSEMBLY STEP # 3 / UPPER HOPPER

#	PART#	DESCRIPTION	QTY.
1	29.42.27455	HOPPER ANTI-SPILL BRACE	4
2	29.42.26406	LOWER CORNER PLATE	4
3	29.42.26453	UPPER CORNER PLATE	4
4	29.42.33452	BOTTOM HOPPER SIDE PANEL	2
5	29.46.27456	HOPPER WINDOW	2
6	29.39.33460	CROSSBAR	2
7	29.42.33453	FRONT PLATE - HOPPER REAR SHEET	2
8	98.002.079025	HEX HEAD SCREW, G5 5/16" X 1 " BSW	100
9	98.304.151079	LOCK NUT, G5 5/16" BSW	100
10	98.309.100079	ZINC PLATED FLAT, 5/16"	200

ASSEMBLY STEP # 3 / UPPER HOPPER

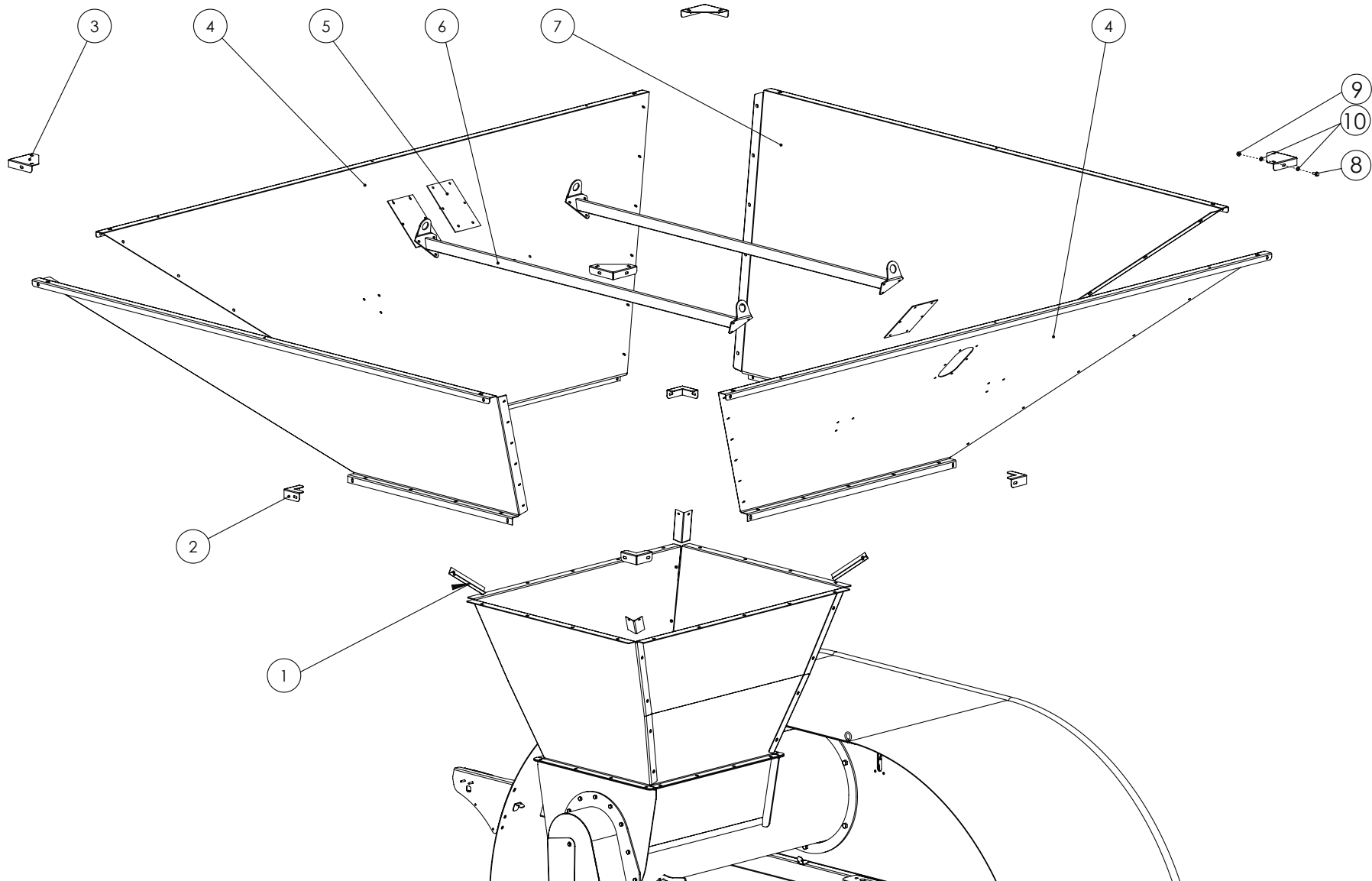

ASSEMBLY STEP # 4 / HYDRAULIC TRAY

#	PART#	DESCRIPTION	QTY
1	98.304.151127	LOCK NUT. G5. 1/2" BSW	8
2	98.309.101127	ZINC PLATED FLAT, 1/2"	8
3	26.43.23375	U-BOLT	4
4	98.002.190114	HEX HEAD SCREW, G5 3/4" X4 1/2" BSW	4
5	98.304.151190	LOCK NUT. G5. 3/4" BSW	4
6	98.309.100190	FLAT WASHER, 3/4"	8
7	29.46.33216	RETAINER RUBBER F/G RAIN	1
8	98.002.095025	HEX HEAD SCREW, G5 3/8"x 1" BSW	16
9	98.310.100095	GROWER WASHER, 3/8"	16
10	29.42.33221	LEFT RUBBER SUPPORT	2
11	29.29.33750	HYDRAULIC TRAY ASSEMBLY	1
12	29.43.33145	U-BOLT	1
13	29.42.33222	RIGHT RUBBER SUPPORT	1
14	98.309.100095	ZINC PLATED FLAT, 3/8"	16
15	29.42.33223	CENTRAL RUBBER SUPPORT	1
16	29.39.23790	TRAY LOCK PIN WITH CHAIN	1

ASSEMBLY STEP # 4 / HYDRAULIC TRAY

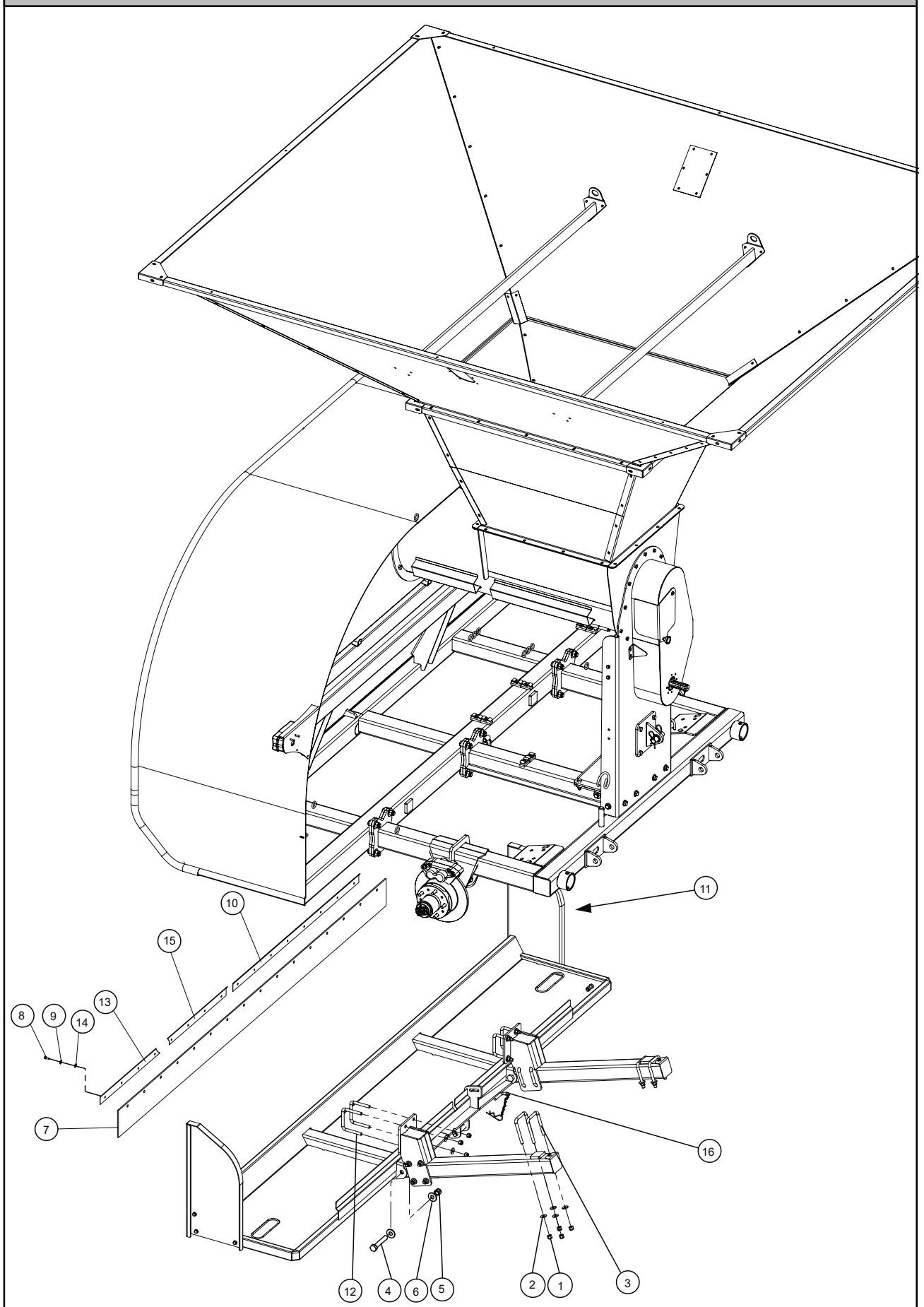

ASSEMBLY STEP # 4 / HYDRAULIC TRAY

#	PART#	DESCRIPTION	QTY
1	29.39.33751	WELDED TRAY ASSEMBLY	1
2	29.39.23775	LEFT SIDE RETAINER	1
3	98.309.100095	ZINC PLATED FLAT, 3/8"	10
4	98.002.095025	HEX HEAD SCREW, G5 3/8"X 1" BSW	2
5	98.002.095050	HEX HEAD SCREW, G5 3/8" X 2" BSW	4
6	29.39.23770	RIGHT SIDE RETAINER	1
7	98.304.110095	LOCK NUT. G5. 3/8" BSW	10
8	98.304.151127	LOCK NUT. G5. 1/2" BSW	24
9	98.309.101127	ZINC PLATED FLAT, 1/2"	24
10	29.39.23785	OUTER SQUARE - TUBE ASSEMBLY	2
11	26.43.23375	U-BOLT	8
12	29.39.33160	REAR SUPPORT ASSEMBLY- LEFT SIDE	1
13	29.39.33165	REAR SUPPORT ASSEMBLY- RIGHT SIDE	1
14	98.378.023974	HYDRAULIC CYLINDER, 2" BORE - 600ML STROKE	1
15	29.43.23137	CYLINDER PIN - TRAY	1
16	29.56.30944	CYLINDER HOSE	2
17	29.43.30875	CYLINDER PIN - TRAY	1
18	98.378.060136	ADAPTER, M/M 1/4" NPT X 9/16 JIC-REDUCED: Ø1.25MM	4

ASSEMBLY STEP # 4 / HYDRAULIC TRAY

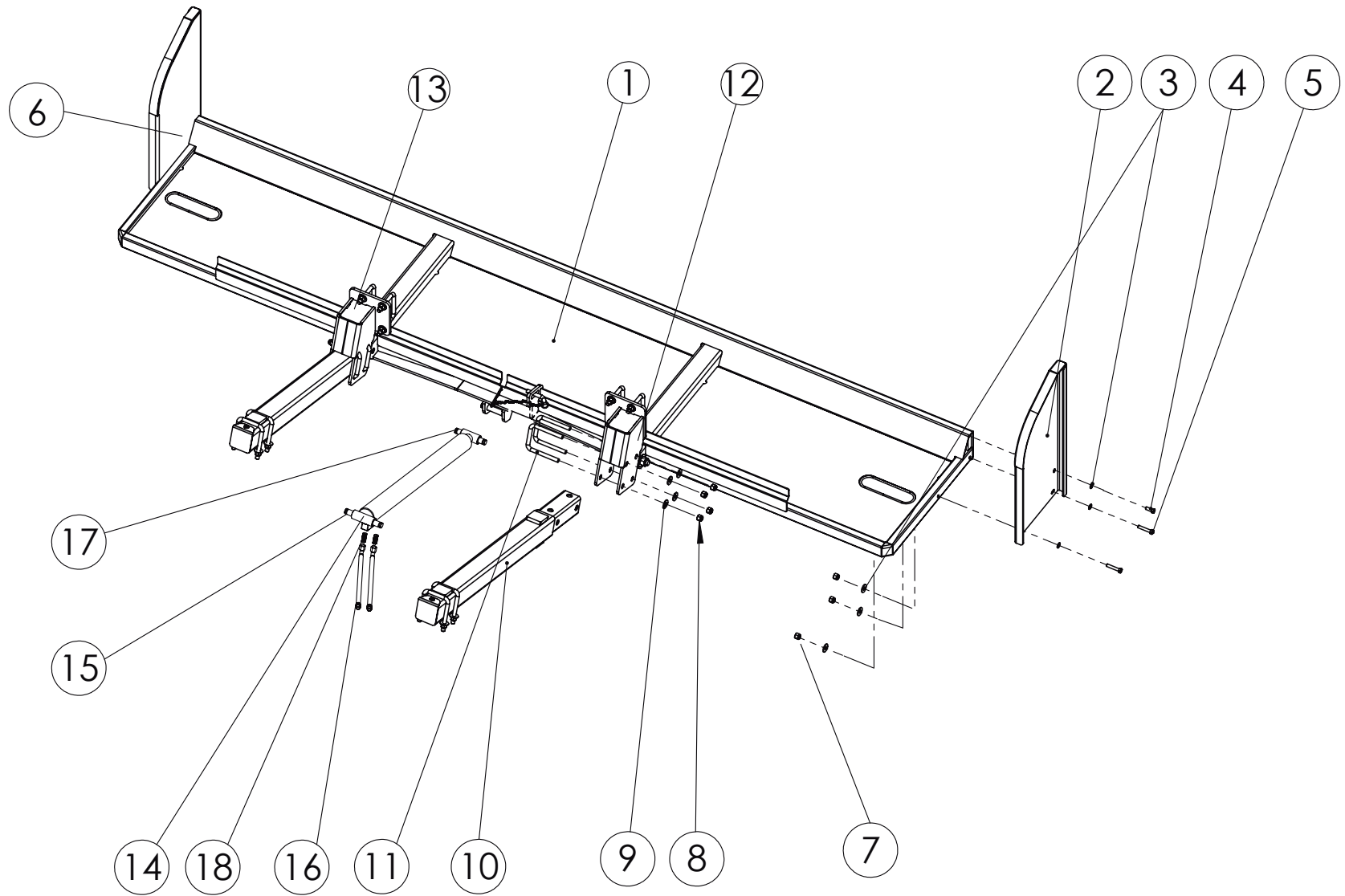

ASSEMBLY STEP # 5 / EASY LIFT / 29.29.33535

#	PART#	DESCRIPTION	QTY
1	98.002.158044	HEX HEAD SCREW, G5 5/8 "x 1 3/4" BSW	4
2	98.309.100158	FLAT WASHER, 5/8"	4
3	29.56.27209	RUBBER CABLE GROMMET	1
4	98.002.095032	HEX HEAD SCREW, G5 3/8" X 1 1/4" BSW	4
	98.304.110095	LOCK NUT, G5 3/8" BSW	4
	98.309.101095	FLAT WASHER, 3/8"	4
5	29.43.27212	PULLEY SPACER	2
6	98.705.305265	BEARING, 6202 2RS	1
7	98.322.000350	SEEGERRING, FOR Ø35 HOLE	1
8	29.41.27211	LIFT SYSTEM PULLEY	1
9	29.39.27285	PULLEY SUPPORT	1
10	98.002.158102	HEX HEAD SCREW, G5 9/16"x4 1/2" BSW	1
11	98.395.028280	WARN ELECTRIC WHINCH	1

ASSEMBLY STEP # 5 / EASY LIFT / 29.29.33535

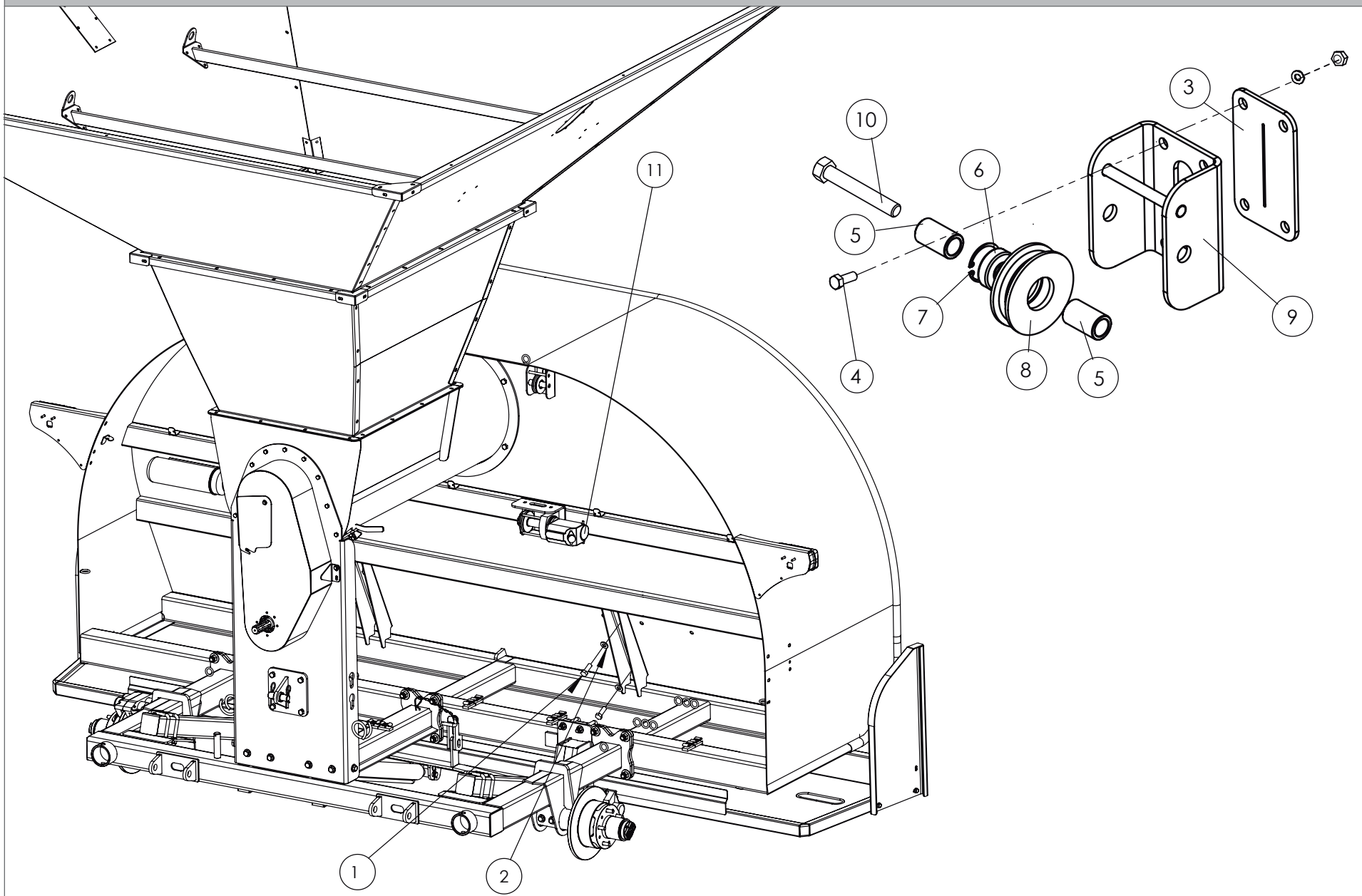

ASSEMBLY STEP # 5 / EASY LIFT / 29.29.33535

#	PART#	DESCRIPTION	QTY
1	98.304.110158	LOCK NUT, G5 5/8" BSW	4
2	29.39.33585	EMD LEFT SUPPORT	1
3	29.39.33586	EMD RIGHT SUPPORT	1
4	98.309.100158	FLAT WASHER, 5/8"	4

ASSEMBLY STEP # 5 / EASY LIFT / 29.29.33535

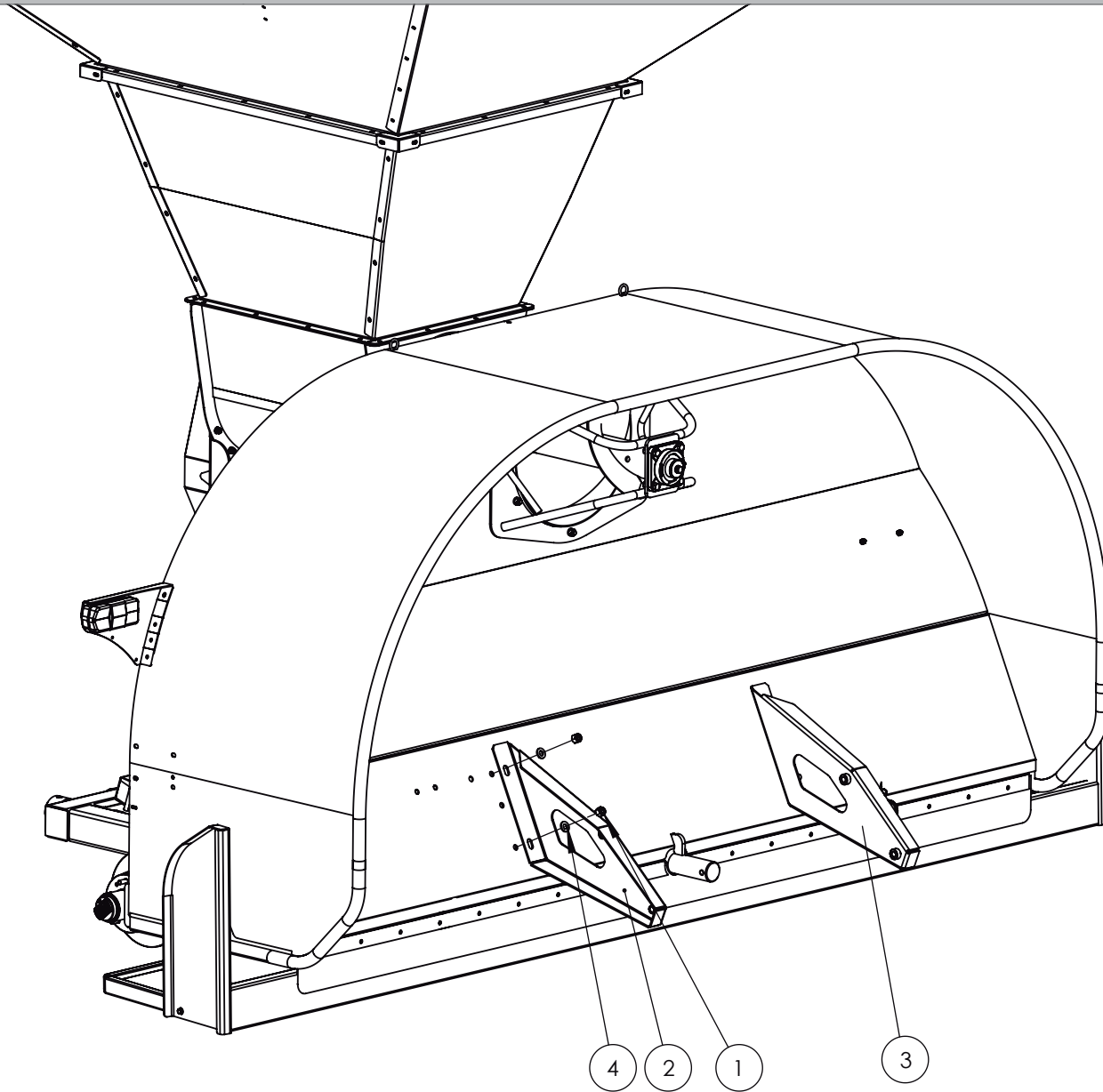

ASSEMBLY STEP # 5 / EASY LIFT / 29.29.33535

#	PART#	DESCRIPTION	QTY
1	98.304.110158	LOCK NUT, G5 5/8" BSW	2
2	98.002.158114	HEX HEAD SCREW, G5 5/8"x4 1/2" BSW	2
3	29.39.27550	CRADLE BRACE	1

ASSEMBLY STEP # 5 / EASY LIFT / 29.29.33535

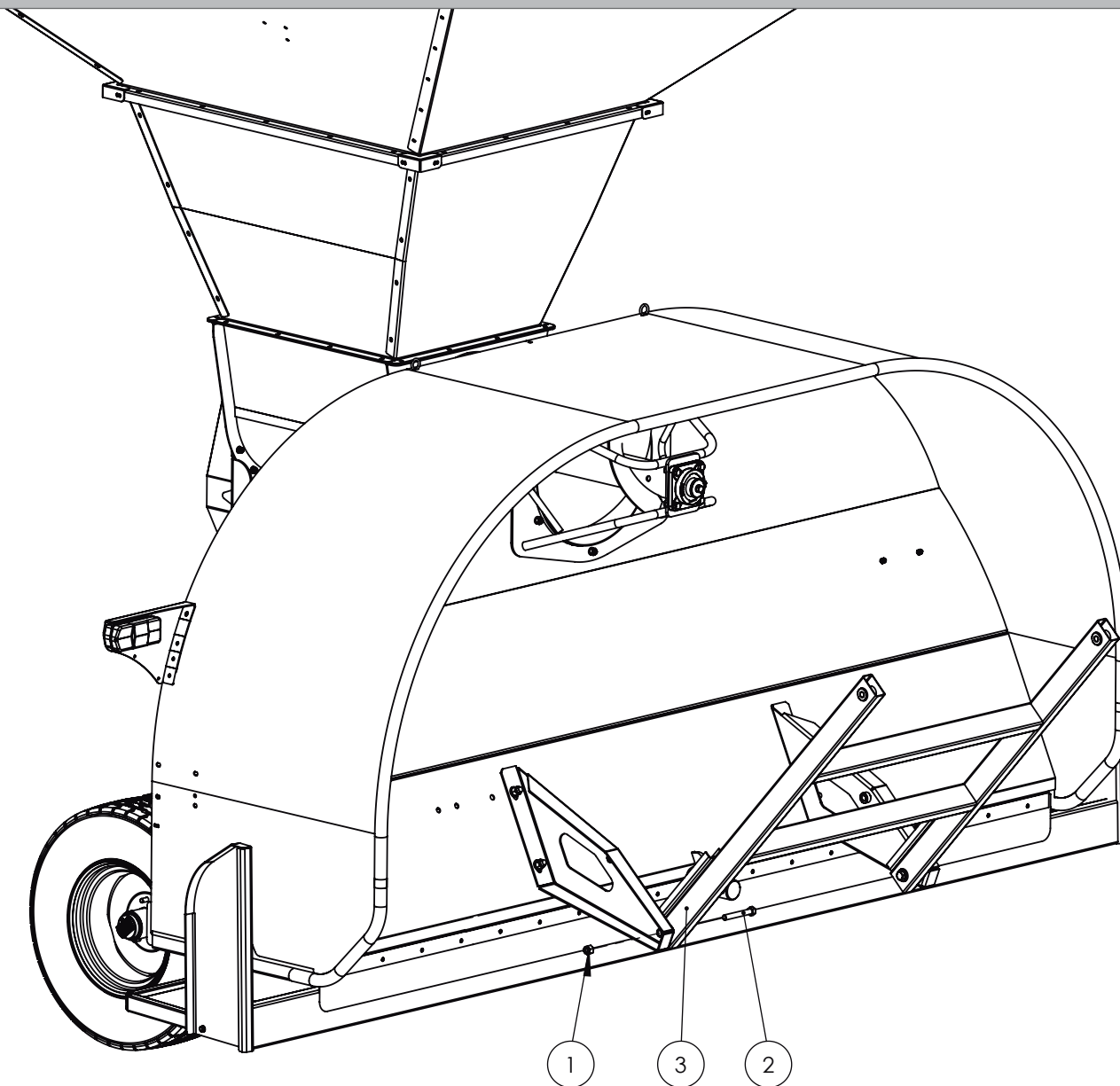

ASSEMBLY STEP # 5 / EASY LIFT / 29.29.33535

#	PART#	DESCRIPTION	QTY
1	98.304.110158	LOCK NUT, G5 5/8" BSW	2
2	98.002.158114	HEX HEAD SCREW, G5 5/8"x4 1/2" BSW	2
3	29.39.27555	PARALLEL LINK ARM	1

ASSEMBLY STEP # 5 / EASY LIFT / 29.29.33535

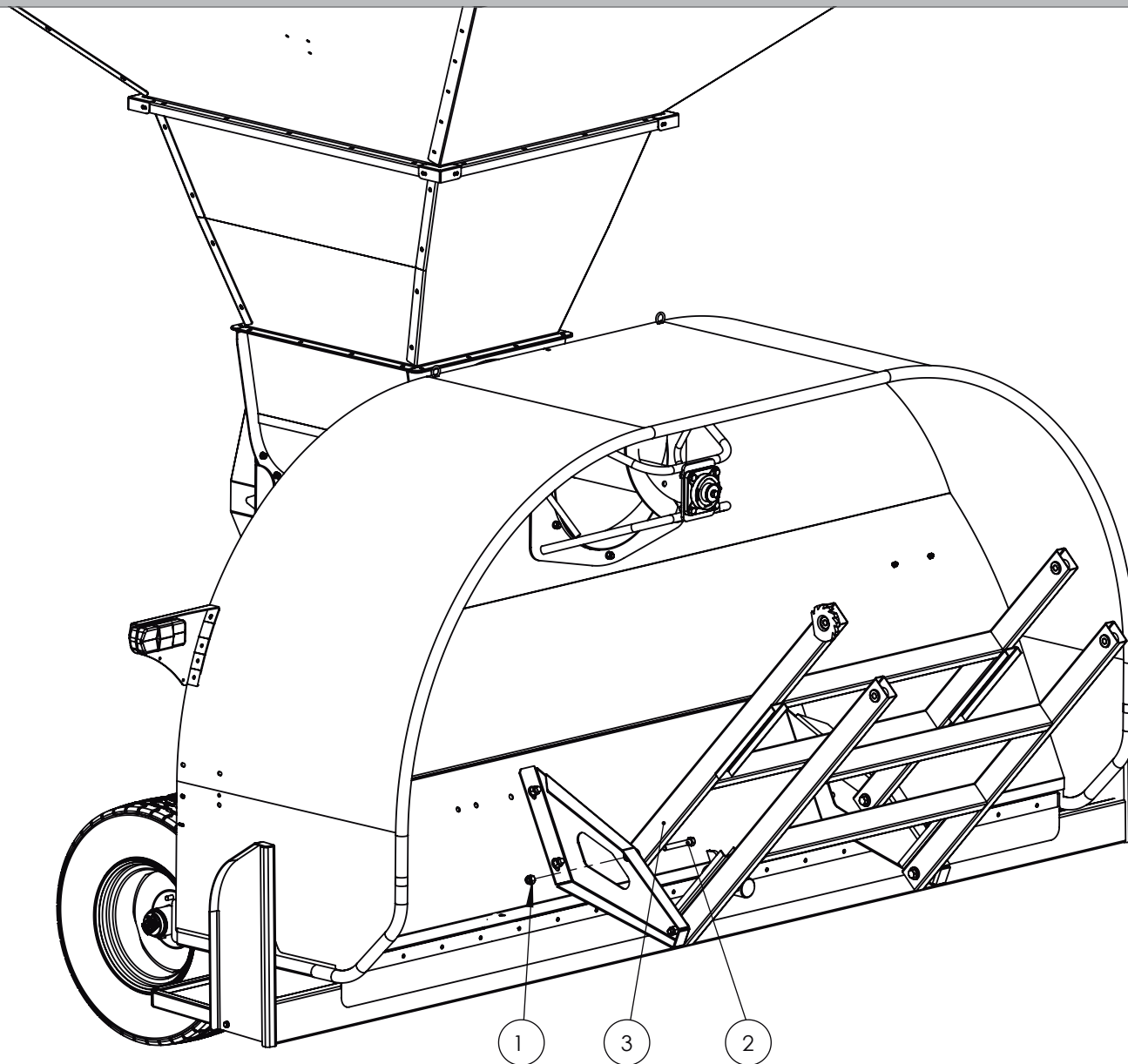

ASSEMBLY STEP # 5 / EASY LIFT / 29.29.33535

#	PART#	DESCRIPTION	QTY
1	98.304.110158	LOCK NUT, G5 5/8" BSW	4
2	29.39.28565	EMD RIGHT BRACE	1
3	98.002.158102	HEX HEAD SCREW, G5 G5 5/8"x 4" BSW	2
4	98.002.158114	HEX HEAD SCREW, G5 5/8"x 4 1/2" BSW	2
5	29.39.28567	RIGHT CRADLE BRACE	2
6	29.39.28570	LEFT SIDE HANGER SUPPORT WITH LOCK	1
7	29.39.27570	CRADLE LATCH	1
8	98.002.127102	HEX HEAD SCREW, G5 9/16"x 4 1/2" BSW	1
9	98.395.028280	CRADLE BUSHING	1
10	29.39.28580	HANGER PULLEY ASSEMBLY	1
11	98.304.151127	LOCK NUT, G5 1/2" BSW	1

ASSEMBLY STEP # 5 / EASY LIFT / 29.29.33535

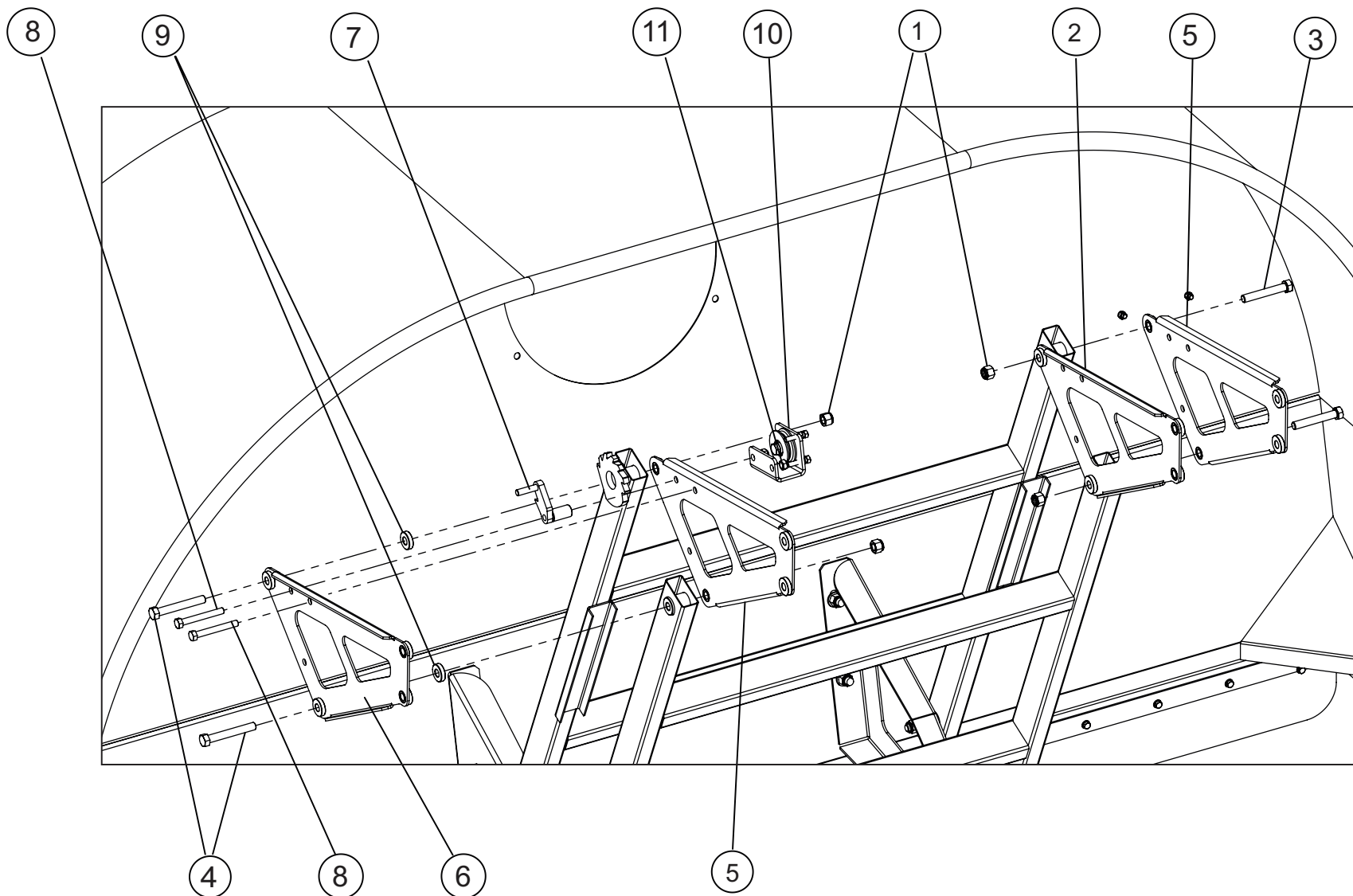

ASSEMBLY STEP # 5 / EASY LIFT / 29.29.33535

#	PART#	DESCRIPTION	QTY
1	29.39.23540	CRADLE	1
2	98.304.110158	LOCK NUT, G5 5/8" BSW	4
3	98.002.158102	HEX HEAD SCREW, G5 G5 5/8"x4" BSW	4
4	29.43.27577	CRADLE BUSHING	2

ASSEMBLY STEP # 5 / EASY LIFT / 29.29.33535

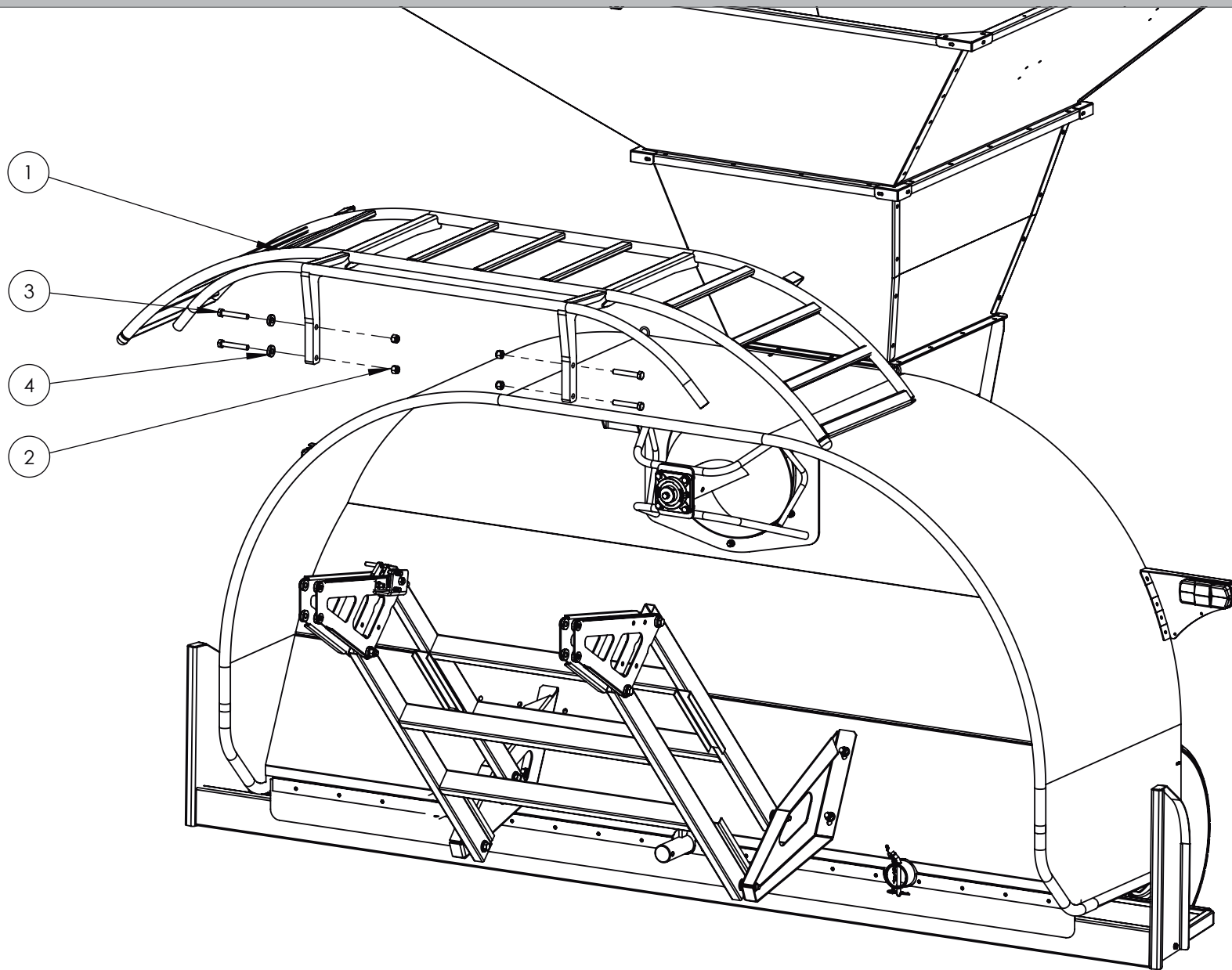

ASSEMBLY STEP # 5 / EASY LIFT / 29.29.33535

#	PART#	DESCRIPTION	QTY
1	29.43.27579	CRADLE LEAF SPRING BUSHING	2
2	98.304.110158	LOCK NUT, G5 5/8" BSW	2
3	98.342.027568	CRADLE LEAF SPRING	2
4	98.002.158102	HEX HEAD SCREW, G5 G5 5/8"x4" BSW	2
5	98.395.028170	AM500 JACK	1
6	25.39.14280	LONG PIN WITH CHAIN	1

ASSEMBLY STEP # 5 / EASY LIFT / 29.29.33535

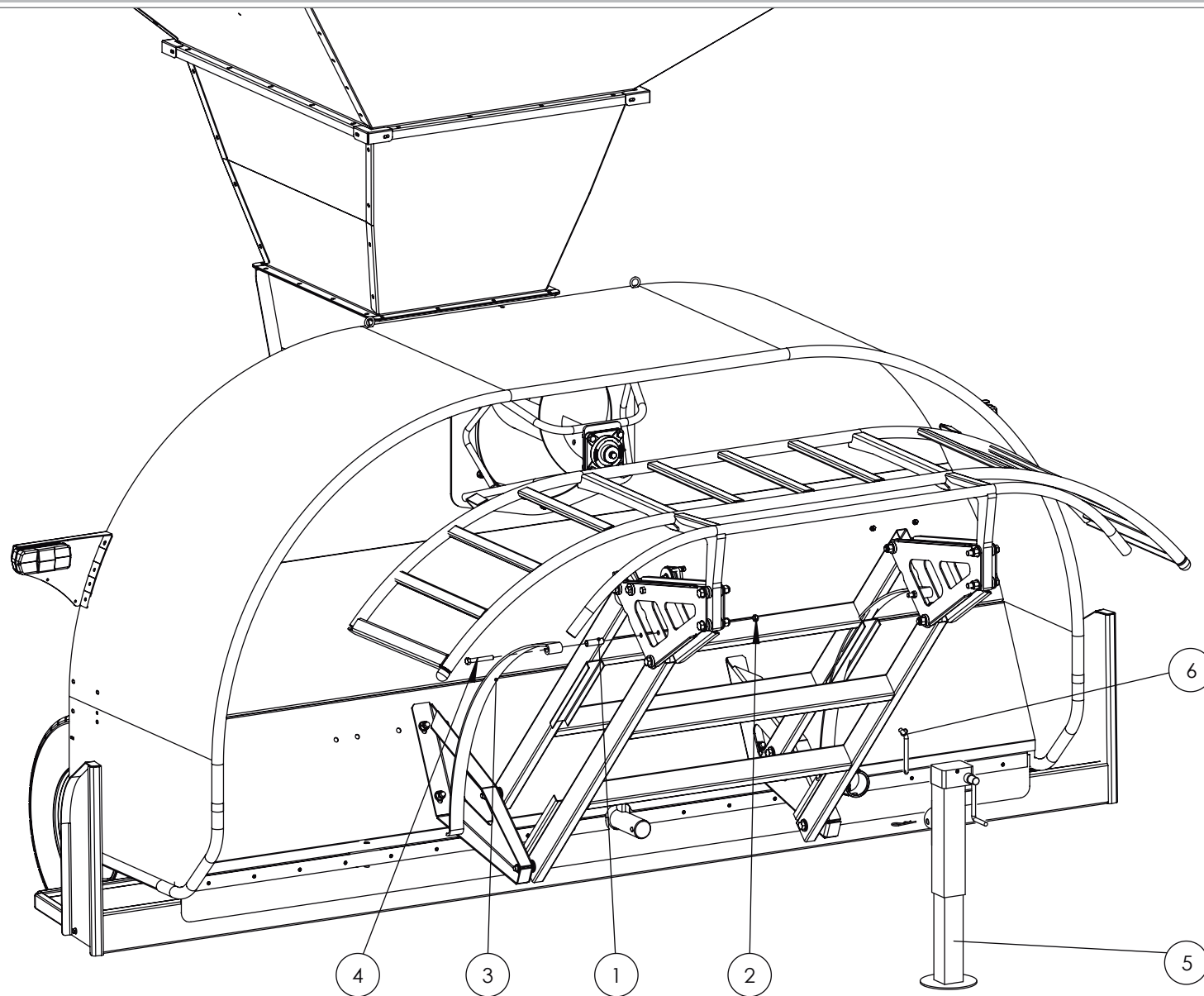

ELECTRICAL WINCH INSTALLATION

- UNWIND AND REMOVE THE CABLE ROPE FROM THE ELECTRIC WINCH.
- CUT THE CABLE ROPE TO A LENGTH OF 6.30 MTS.
- ATTACH THE CABLE ROPE HOOK TO THE BOW SHACKLE.

STEP 1

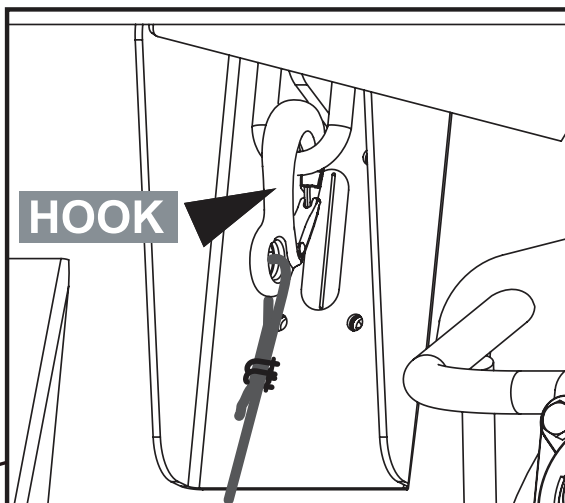

STEP 2

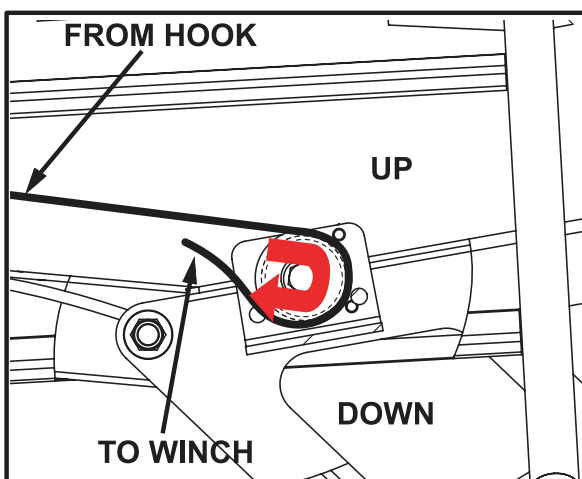
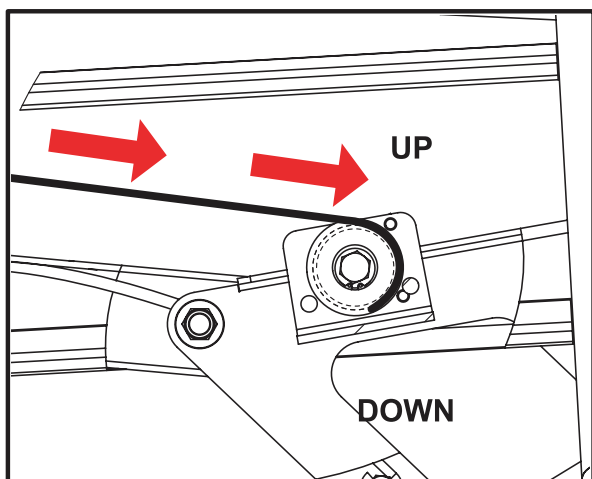
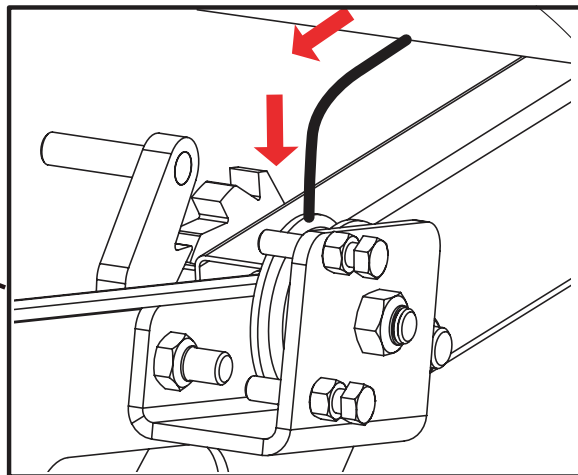

ONCE THE CABLE ROPE HAS BEEN PASSED THROUGH THE HOLE AS SHOWN IN STEP # 3, GUIDE THE WIRE ROPE THROUGH THE PULLEY AS SHOWN IN STEP #4.



STEP 3

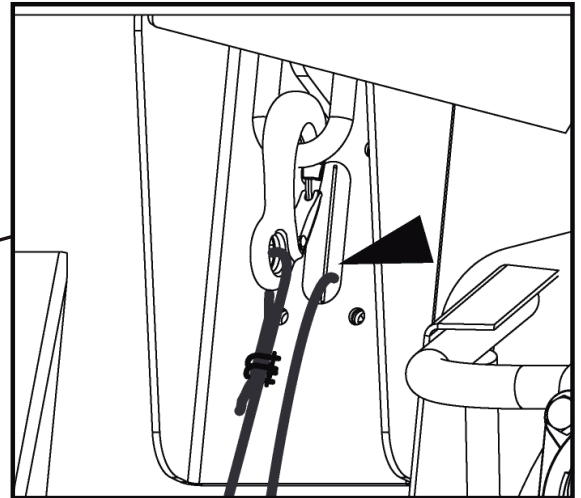

STEP 4

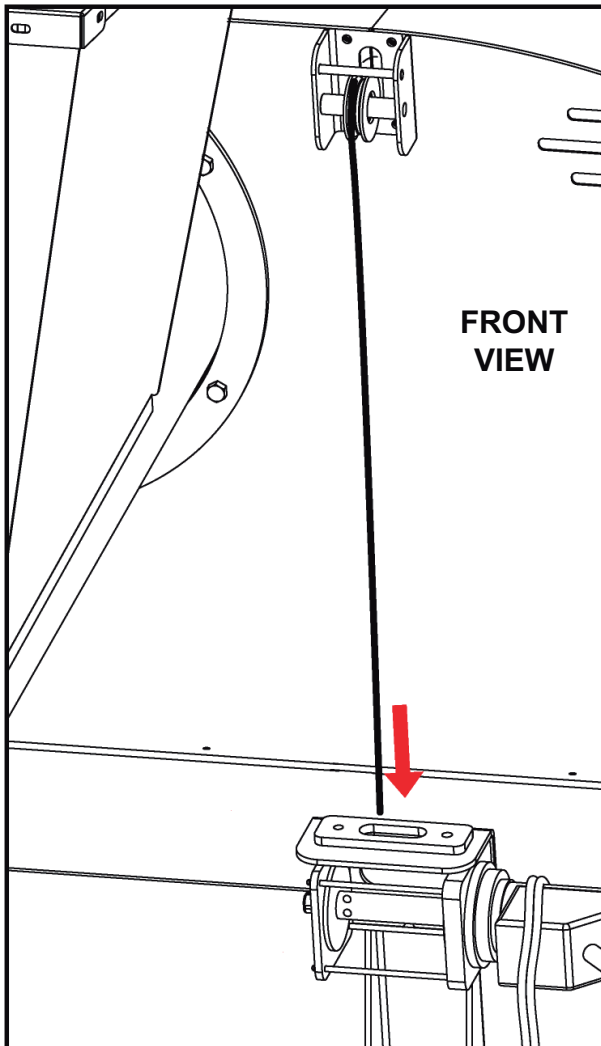

ELECTRIC WINCH SUPPORT BOLTS:

98.037.095025: HEX-SOCKET HEAD CAP SCREW, 3/8" X 1" BSW - QTY:3

98.304.151095: LOCK NUT G5 3/8" BSW - QTY: 3

98.309.101095: FLAT WASHER, 3/8" YELLOW ZINC PLATED QTY: 3

SET OF COMMERCIAL PARTS - BAG N°7 - 29.39.50227

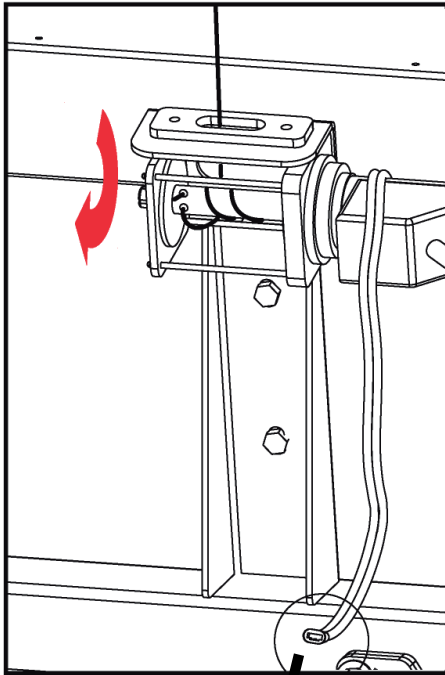

STEP 5
MAKE AN ADDITIONAL HOLE ON THE WINCH CABLE ROPE DRUM. GET THE CABLE ROPE THROUGH THE HOLES AND FIX IT WITH A STUD BOLT.

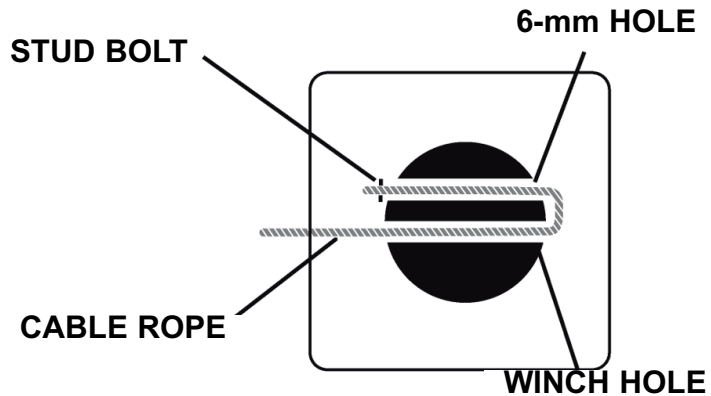

ROTATE THE CABLE ROPE DRUM COUNTER CLOCKWISE SO THE CABLE ROPE DOES NOT RUB AGAINST THE HAWSE FAIRLEAD.

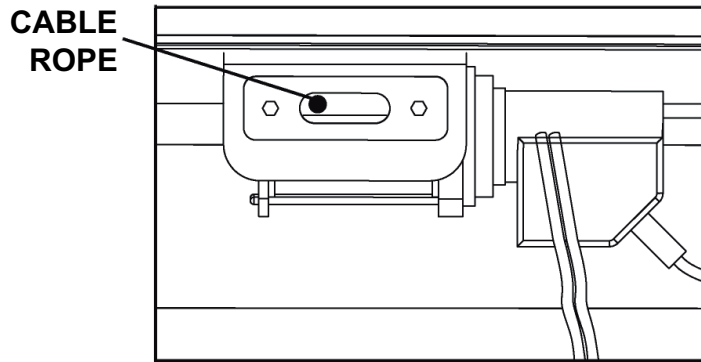

2



3



4

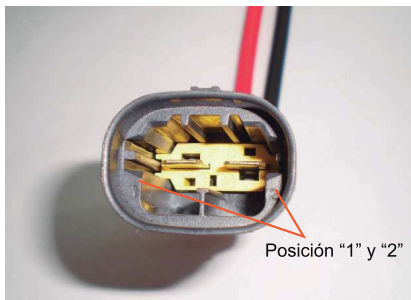

ELECTRICAL WINCH CONNECTION INSTRUCTIONS

- 1 - CUT 1.25 M OF WINCH ELECTRICAL WIRE .
- 2 - PUT THE SEAL AND CONNECT THE TERMINAL TO THE CABLE.
- 3 - INTRODUCE EACH CABLE INTO THE CONNECTOR CORRECT POSITION UNTIL MAKING A CLICK "SOUND". THE RED CABLE GOES IN POSITION "1" WHILE THE BLACK CABLE GOES IN POSITION "2"
- 4 - ONCE THE CONNECTOR IS ASSEMBLED, PRESS THE YELLOW PLASTIC SAFETY LOCK INTO THE CONNECTOR UNTIL MAKING A "CLICK" SOUND.

ASSEMBLY STEP # 6 / TOWBAR / TURNBUCKLE

#	PART#	DESCRIPTION	QTY
1	29.39.26160	TOW HITCH	1
2	98.301.150158	HEX NUT. G5 5/8" BSW	3
3	98.310.100158	LOCK WASHER, 5/8"	3
4	98.380.040090	90MM-LONG Ø4 COT.PIN (Ø5/32"X3-1/2")	9
5	98.002.158063	HEX HEAD SCREW, G5 5/8" x 2 1/2" BSW	3
6	29.39.25160	TOWBAR	1
7	29.43.24186	TOWBAR PIN	2
8	29.43.24187	ADJUSTMENT RATCH.ANCHORING PIN	2
9	27.29.80700	TURNBUCKLE ANCHORING PIN	1
10	30.29.39250	DRIVESHAFT F/80 HP	1

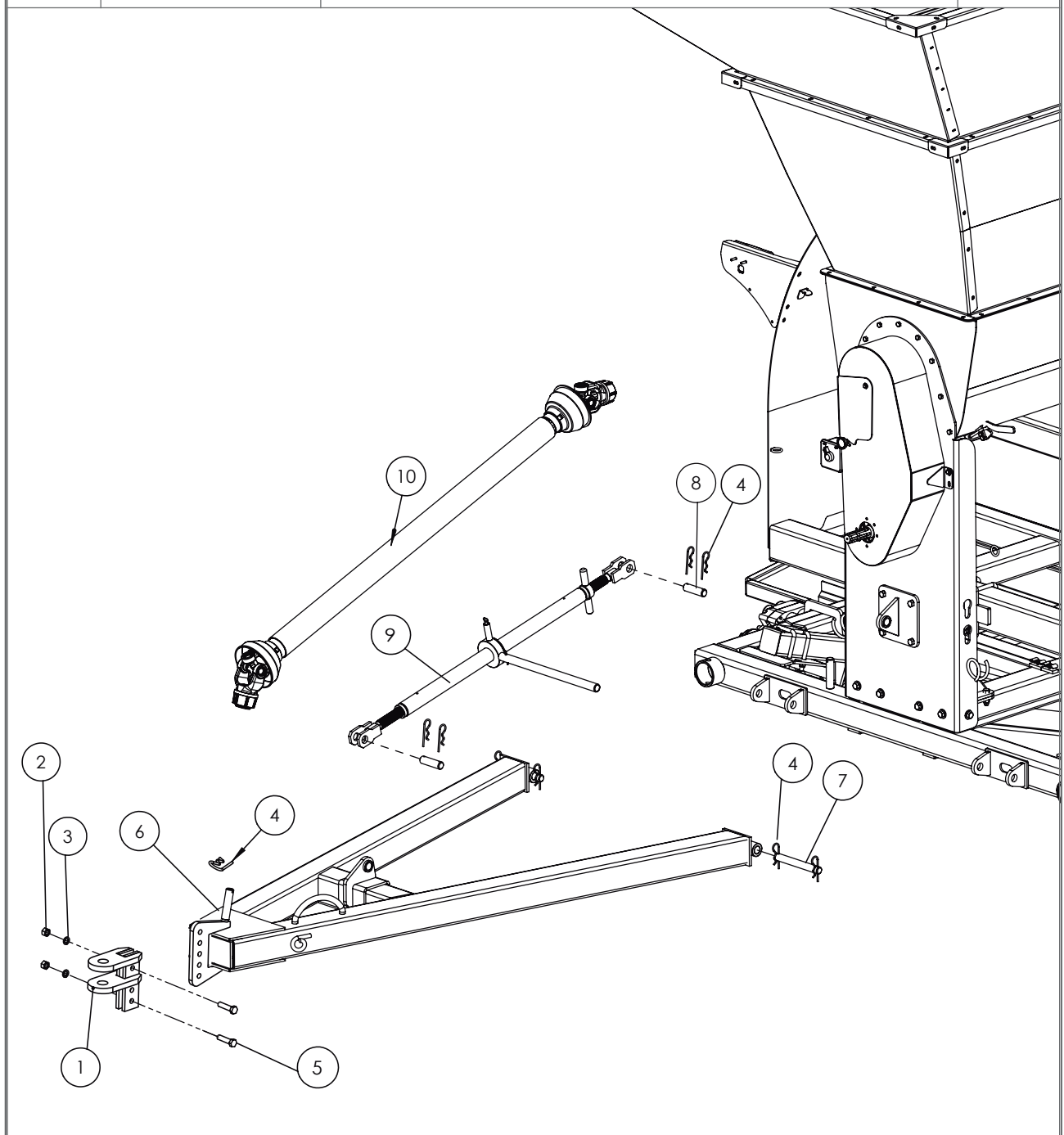

ASSEMBLY STEP # 7 / WHEELS

#	PART#	DESCRIPTION	QTY
1	98.306.350190	WHEEL NUT, WIDE FLANGE 3/4" NF	10
2	29.39.33170	TIRE	2

ASSEMBLY STEP # 7 / WHEELS

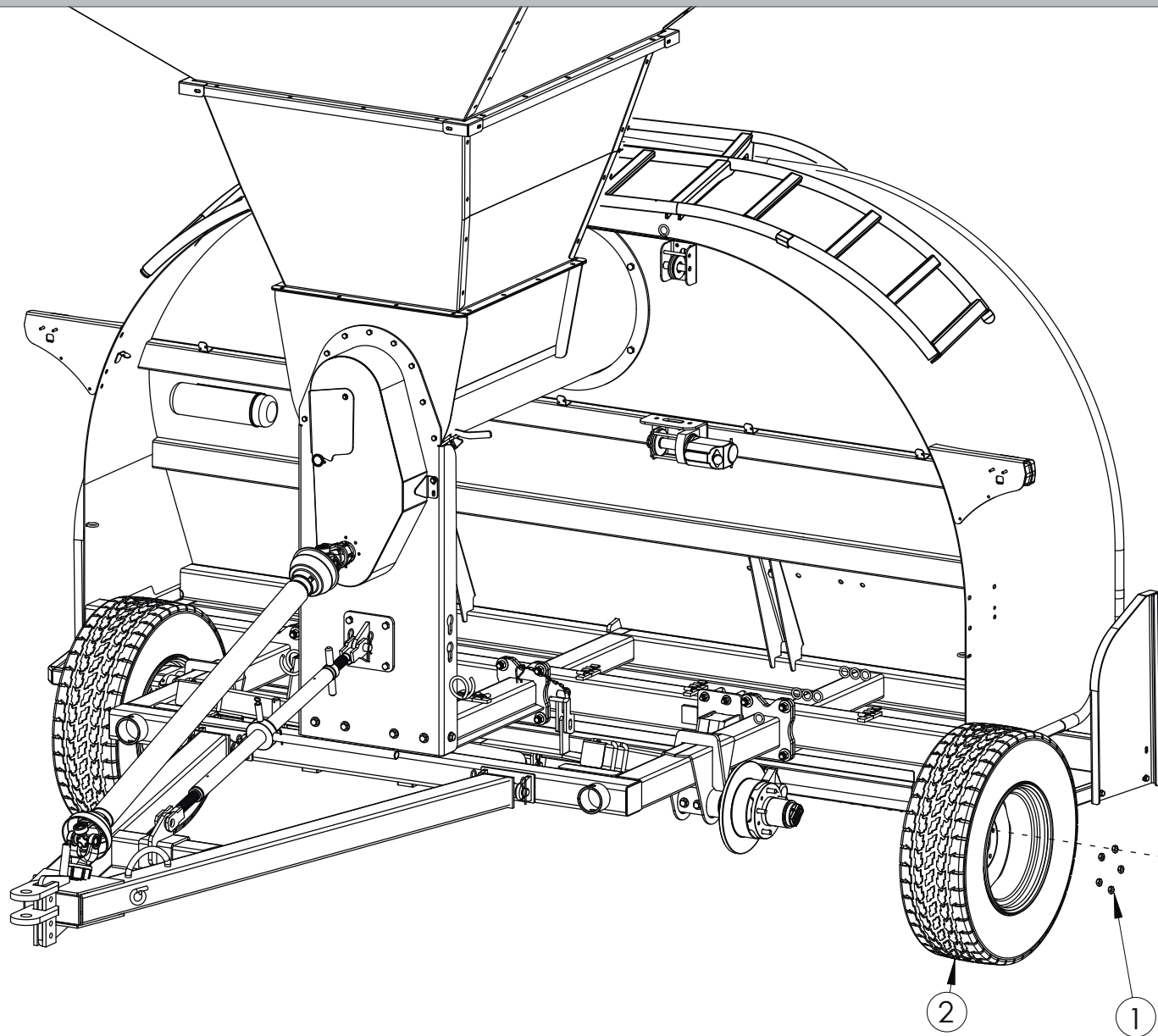

ASSEMBLY STEP # 7 / WHEELS

#	PART#	DESCRIPTION	QTY
1	98.037.127032	ALLEN SCREW, 1 1/4" x 1/2" BSW	5
2	98.310.100127	LOCK WASHER, 1/2"	5
3	29.41.25174	BRAKE DISC	1
4	98.610.175652	DBH 6002 SEAL	1
5	98.730.330945	30209 BEARING	1
6	98.232.127044	SCREW FOR HUB, 1/2" X 3/4" NF	5
7	29.41.25177	WHEEL HUB	1
8	98.730.330735	30207 BEARING	1
9	29.43.25227	WHEEL HUB WASHER	1
10	98.303.311316	CASTLE NUT, 1 1/4" x 12 NF	1
11	98.334.050060	Ø5 X 60MM SPLIT PIN (Ø13/64"x 2-3/8")	1
12	29.41.25175	BRAKE HUB COVER	1
13	98.460.100131	1/4" BSP STRAIGHT GREASE FITTING	1
14	98.662.085116	265 70 R16 TYRE	1
15	98.395.033171	5 HOLE 16"X8" AG RIM	1
16	98.306.350190	WHEEL NUT, WIDE FLANGE 3/4" NF	10
17	29.39.25168	HUB WITH DISC BRAKE ASSEMBLY	1
18	29.39.33170	TIRE	2
19	29.39.33125	SPINDLE ASSEMBLY	2
20	98.002.127114	HEX HEAD SCREW, G5 1/2 X 4/12" BSW	2
21	98.309.101127	FLAT WASHER, 1/2"	4
22	98.304.151127	LOCK NUT, G5 1/2" BSW	2

ASSEMBLY STEP # 7 / WHEELS

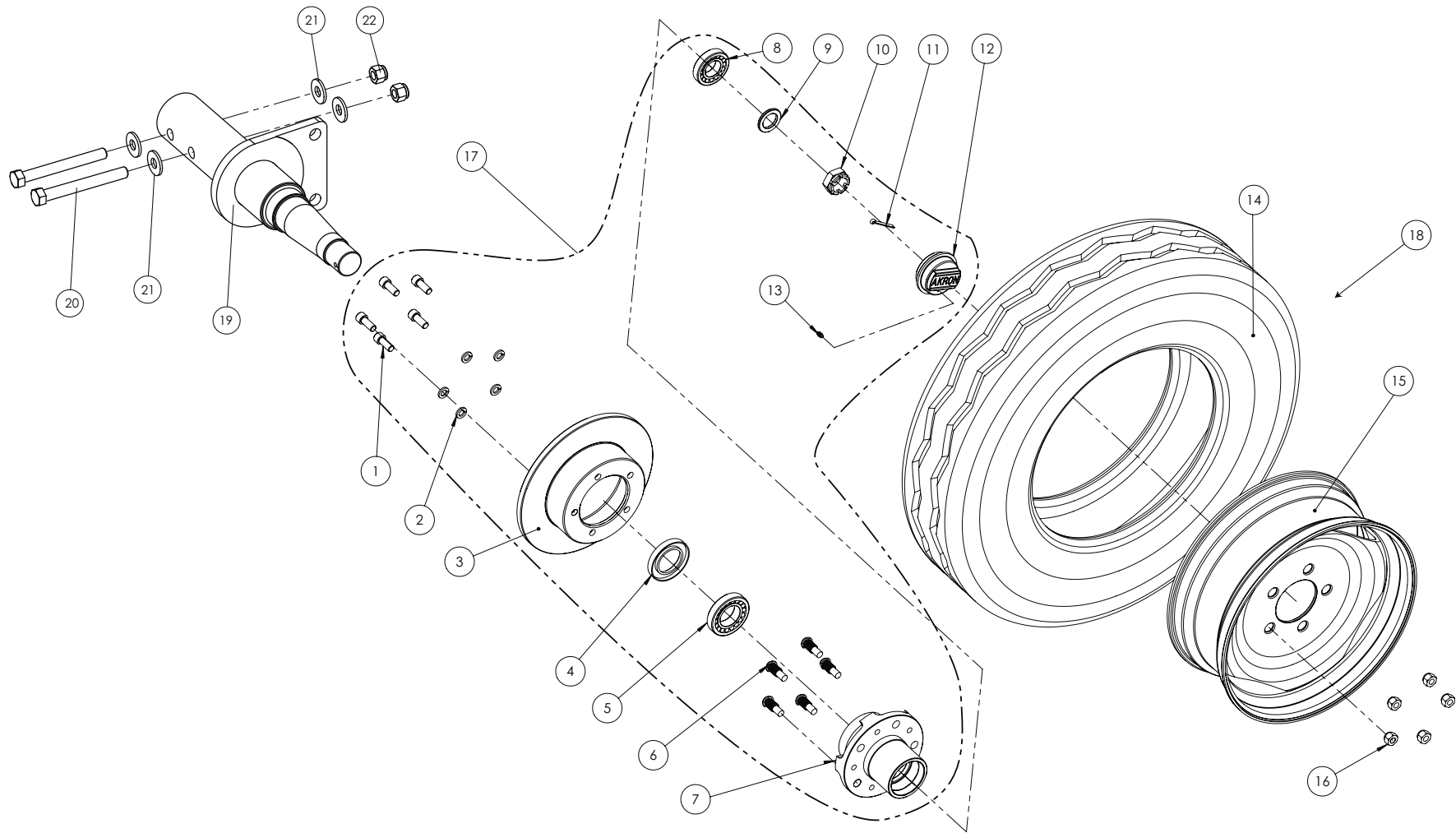

ASSEMBLY STEP # 8 / TRANSMISSION

#	PART#	DESCRIPTION	QTY
1	29.39.33440	CHAIN COVER	1
2	29.39.33360	ASA 80-2 CHAIN -1"	1
3	98.002.190114	HEX HEAD SCREW, G5 3/4"X4 1/2" BSW	1
4	29.43.30423	ASA 80-2 SPROCKET (Z24)	1
5	98.002.127044	HEX HEAD SCREW, G5 1/2" x 1 3/4" BSW	12
6	98.611.176455	10322 SAV SEAL	1
7	98.713.214655	2311 BEARING	1
8	29.41.27381	FRONT AUGER SUPPORT	1
9	98.061.079032	5/16" x 1 1/4" W STUD	2
10	98.301.150079	HEX. NUT, G5 5/16" BSW	2
11	98.310.100190	LOCK WASHER, 3/4"	1
12	98.322.001200	SEEGER RING Ø 120	1
13	98.611.178084	10279 SAV SEAL	1
14	98.705.206530	6206 BEARING	2
15	25.43.25717	TENSIONER SPACER	1
16	25.39.21732	TENSIONER	1
17	98.301.150127	HEX. NUT, G5 1/2" BSW	8
18	98.309.100127	FLAT WASHER, 1/2"	1
19	29.43.30425	KEY	1
20	98.304.350254	LOCK NUT, G5 NF1"X14H	1
21	29.43.30402	SPLINED INLET SHAFT	1
22	98.310.100127	LOCK WASHER, 1/2"	6
23	29.43.30711	BEARING SHAFT	1
24	29.43.27404	SEAL HOLDER	1
25	98.611.176152	7280 SAV SEAL	2
26	25.43.21712	BEARING SPACER	1
27	98.705.207645	6209 BEARING	3
28	29.43.30713	CHAIN TENSIONER END WASHER	1
29	29.43.27403	BEARING SPACER BUSHING	1
30	29.41.27401	INLET SHAFT SUPPORT BSW	1
31	29.43.30405	KEY	1
32	98.002.079025	HEX HEAD SCREW 5/16" X 1" BSW	3
33	98.304.151079	LOCK NUT G5 5/16" BSW	3
34	29.42.25993	BOTTOM COVER HANDLE	1
35	29.39.28420	10-FOOT BAGGER INSPECTION COVER	1
36	29.43.25973	BOTTOM COVER HINGE PIN	1
37	98.334.030030	COTTER PIN, Ø3 X30 YELLOW ZINC PLATED	2

ASSEMBLY STEP # 8 / TRANSMISSION

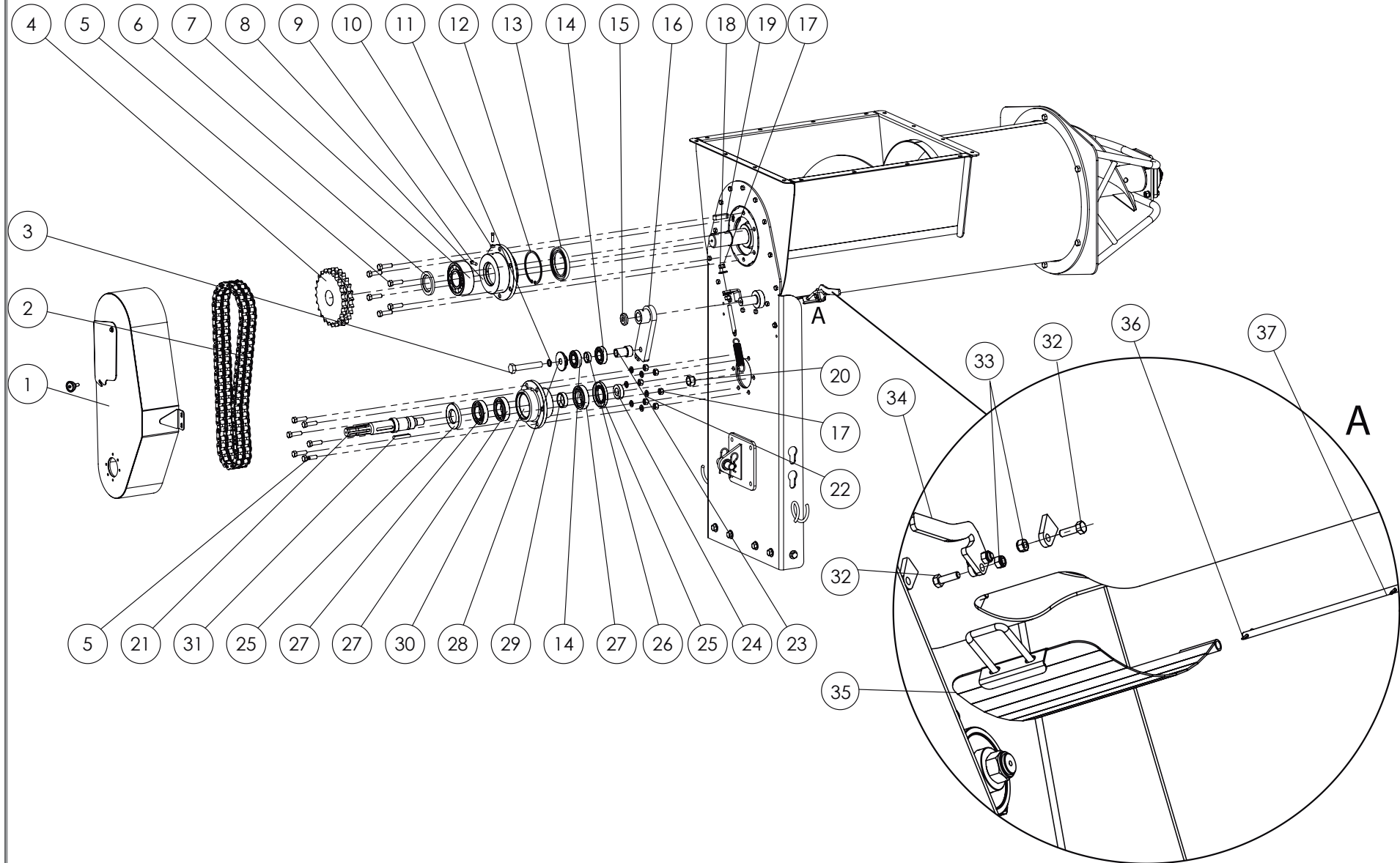

ASSEMBLY STEP # 9 / HYDRAULIC BRAKE SYSTEM

#	PART#	DESCRIPTION	QTY.
1	29.39.28839	WELDED PANEL	1
2	29.43.27806	BRAKE PUMP SUPPLEMENT	1
3	29.42.27807	WHEEL COVER	1
4	29.43.27808	BRAKE PUMP SHAFT	1
5	98.408.027809	BRAKE PUMP HANDWHEEL	1
6	98.395.027808	DODGE BRAKE PUMP WITH F700 PISTON	1
7	98.378.027811	PRESSURE GAUGE, 1/4" NPT	1
8	98.378.027815	BRAKE PRESSURE CONTROL VALVE	1
9	29.43.27804	BRAKE PUMP ACTIVATION NUT	1
10	98.378.071985	FEMALE TEE FITTING, 1/4" NPT	1
11	98.378.054501	37° ELBOW JIC - RING	2
12	29.43.27812	PERFORATED SCREW	1
13	98.378.060135	NIPPLE ADAPTER, 1/4" NPT – 9/16" NF	1
14	98.311.112127	ZINC PLATED FLAT, 1/2"	4
15	98.002.127044	GROOVED BOLT, 1/2" x 1 3/4" NF	4
16	98.395.025735	BRAKE CALIPER, UNIVERSAL MODEL CODE 1000	2
17	29.56.27814	PUMP HOSE	1
18	29.56.33816	1350 HOSE	1
19	29.29.333900	BRAKE SYSTEM	1
20	98.378.071977	TEE FITTING M 9/16" JIC/ M 9/16" JIC/M 9/16"	1
21	29.56.33818	2880 HOSE	1
22	29.56.33817	1125 HOSE	2
23	98.459.010015	ALUMINUM WASHER, Ø 10 MM, THIN FLANGE	2
24	98.378.013967	ADAPTER, M-M 9/16" JIC – 3/8" NF	2
25	98.002.095032	HEX HEAD SCREW, G5 3/8"x1 1/4" BSW	8
26	98.304.151095	LOCK NUT, G5 3/8" BSW	8
27	98.002.079019	HEX HEAD SCREW, G5 5/16" X 3/4" BSW	1
28	98.173.039019	ROUNDED HEAD SCREW, 5/32" X 3/4"	3
29	98.309.100039	FLAT WASHER, 5/32"	3
30	98.310.100039	GROWER WASHER, 5/32"	3
31	98.301.150039	HEX NUT, G5 5/32" BSW	3
32	98.061.063022	STUD BOLT, G8 1/4" X 7/8" BSW	1
33	29.43.27810	HANDWHEEL KEY	1
34	98.304.151127	LOCK NUT, G5 1/2" BSW	4
35	98.309.100095	FLAT WASHER, 3/8"	8

ASSEMBLY STEP # 9 / HYDRAULIC BRAKE SYSTEM

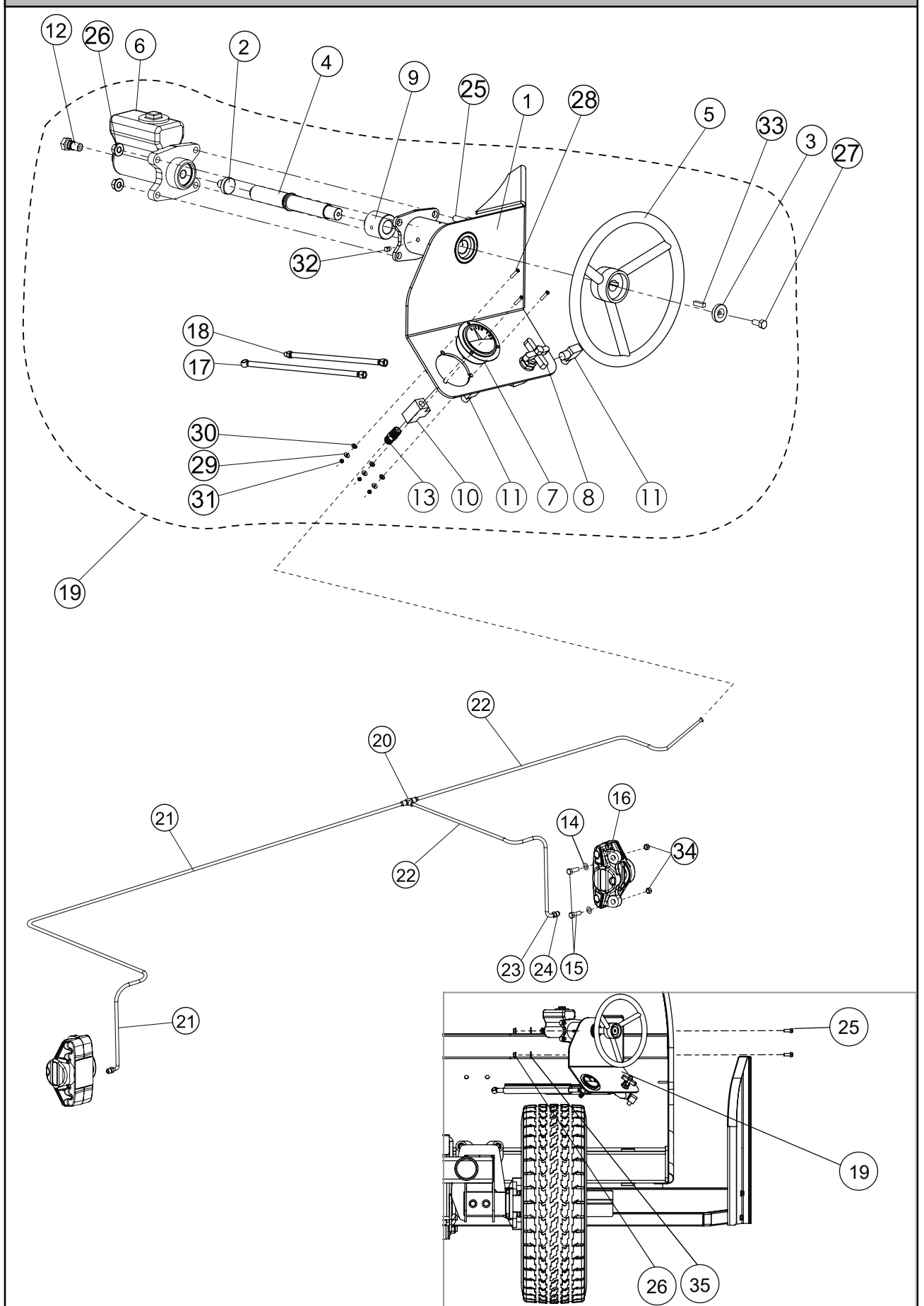

BRAKE CIRCUIT BLEEDING

- 1- Connect the hose from the calipers to the fittings located behind the brake panel.
(4).
- 2- Remove the plug (3) and put the brake fluid provided by the manufacturer into the tank.
- 3- Open the bleed screw of the caliper further from the pump (5)
- 4- Close the switch valve lever (1) and turn the steering wheel (2) all the way counterclockwise (When performing this action, slowly turn the wheel to allow oil to flow through the circuit).
- 5- Open the knob (1) and turn the steering wheel (2) all the way.
- 6- Repeat steps 4 and 5 until there is no sign of air in the fluid flowing through the bleed screw. If after trying this process between 8 and 10 times, no fluid is observed to flow through the bleeder outlet, check that the fittings located behind the brake panel are correctly engaged.
- 7- Close the bleed screw previously opened and follow steps 4 and 5 detailed above with the other caliper (6).

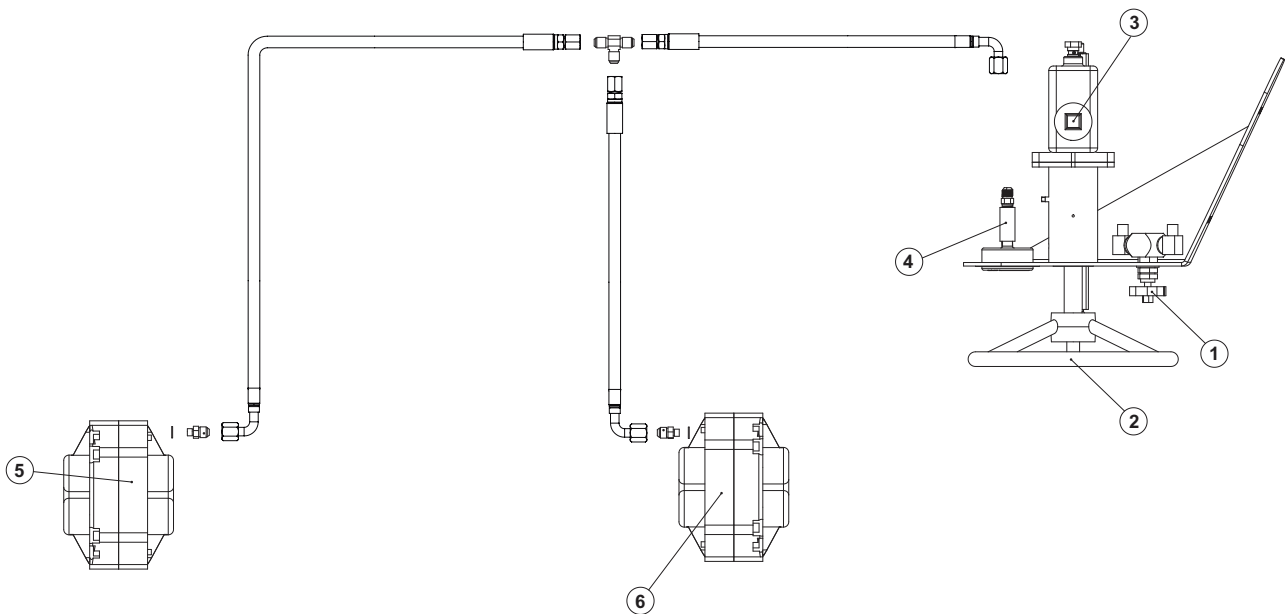

HYDRAULIC SYSTEM

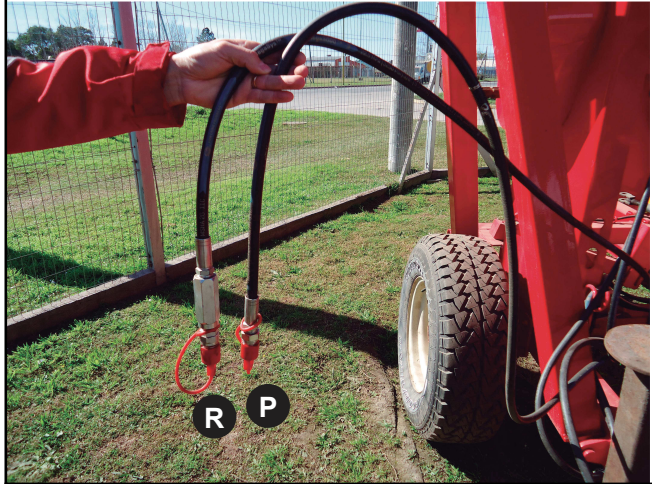
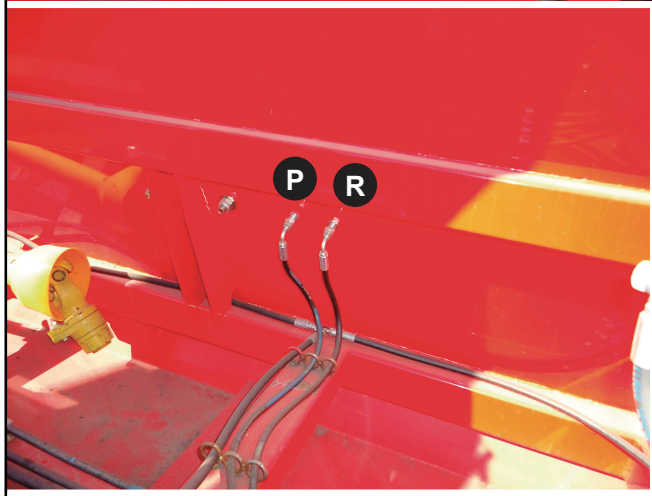
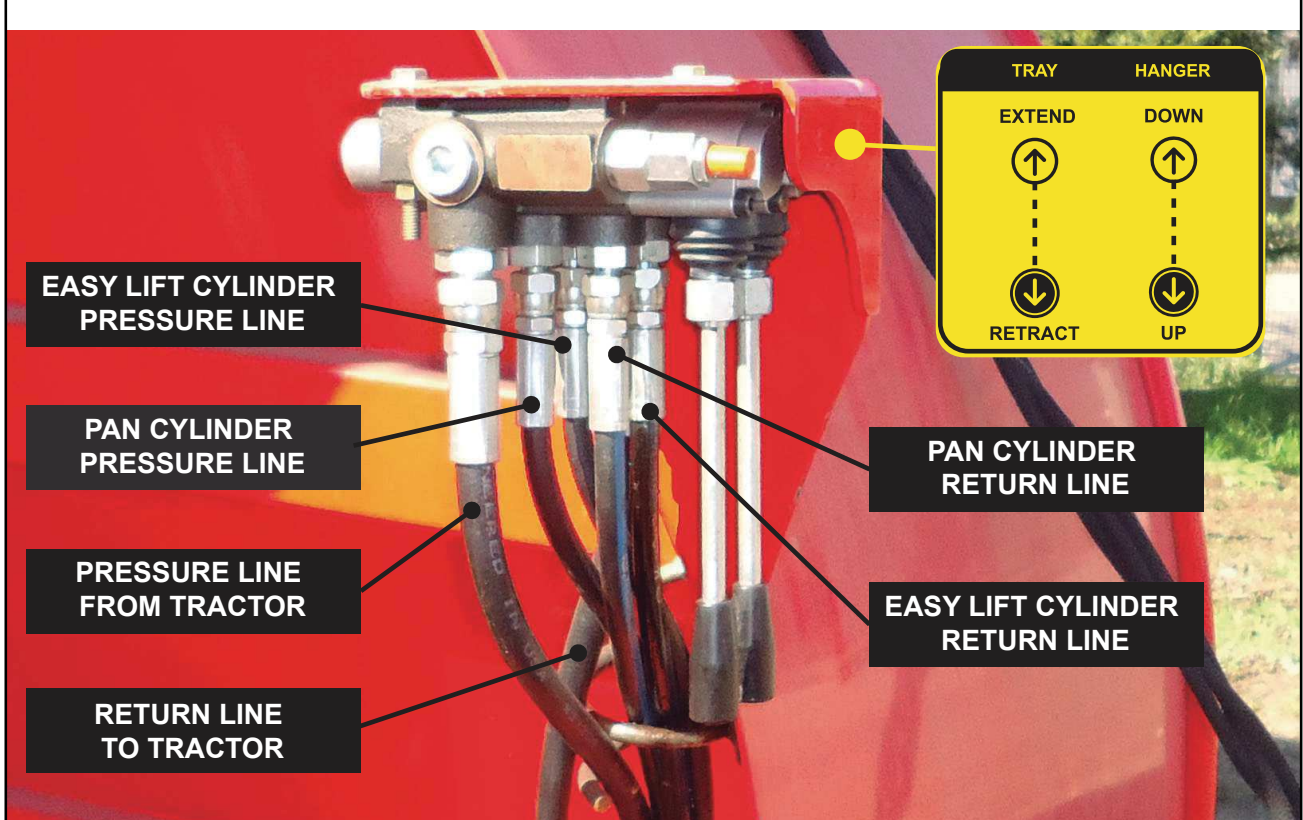

ASSEMBLY STEP # 10 / HYDRAULIC EASY LIFT (OPTIONAL)

#	PART#	DESCRIPTION	QTY
1	98.002.254203	HEX HEAD SCREW, G5 1" X 8" BSW	1
2	29.39.33570	PARALLEL ARM HYDRAULIC CYLINDER	1
3	29.43.33376	CYLINDER PIN	1
4	98.380.040090	90MM-LONG Ø4 COT.PIN (Ø5/32"X3-½")	2
5	29.39.33595	LEFT SIDE SUPPORT ASSEMBLY	3
6	29.39.33350	AUGER ASSEMBLY	1
7	29.29.33580	10 FOOT HYDRAULIC EASY LIFT ASSEMBLY	2

ASSEMBLY STEP # 10 / HYDRAULIC EASY LIFT (OPTIONAL)

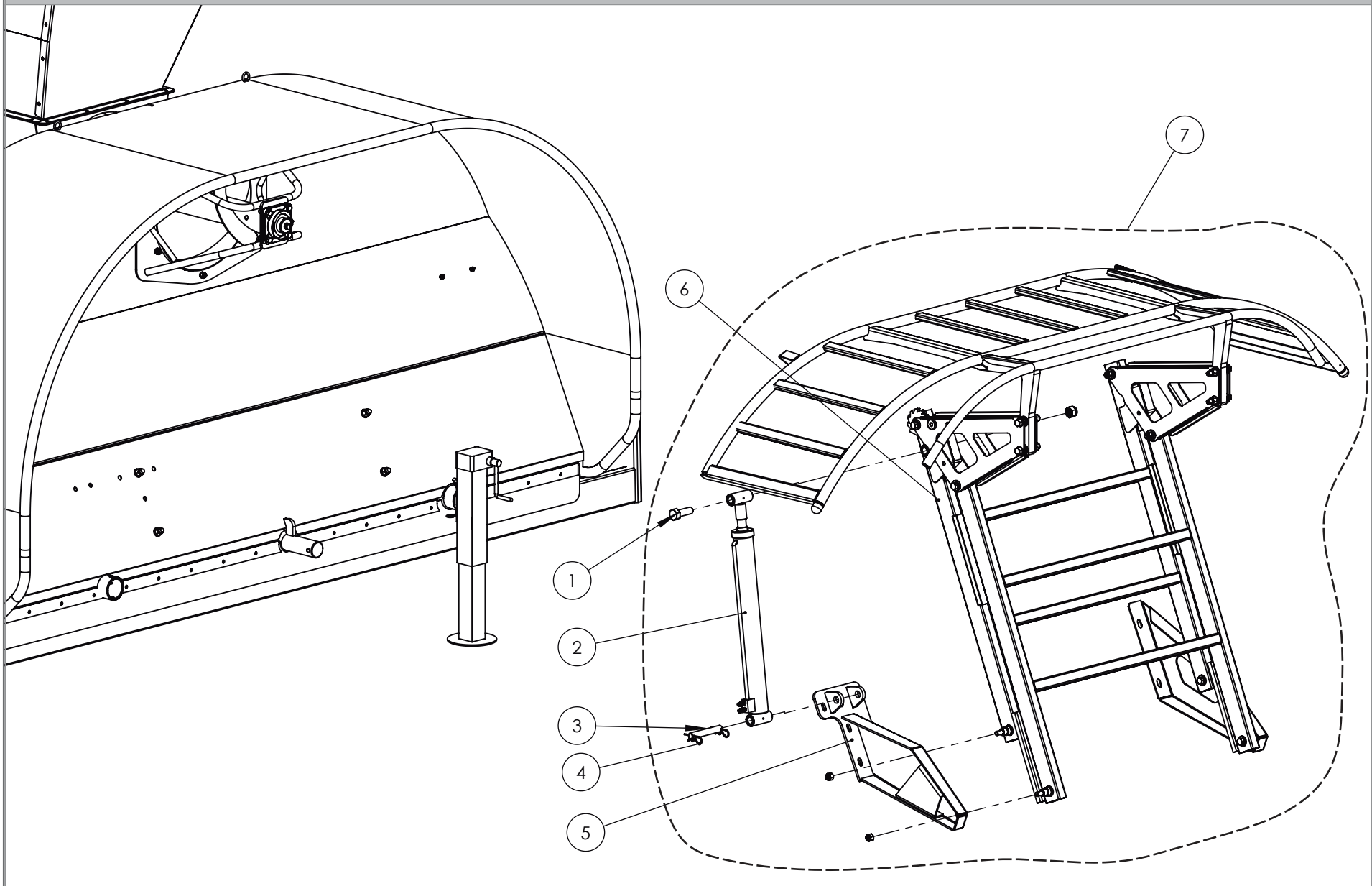

13. PARTS SUBJECT TO NORMAL WEAR AND TEAR

Ordinary maintenance and spare parts replacement services of the parts detailed below are the equipment owner's exclusive responsibility, therefore, they will not be considered defects in material or manufacturing, but rather defects due to normal wear and tear; improper operation or insufficient equipment maintenance.

- Chains
- Augers
- Bearings
- Wheels
- Sprockets
- Brake System (brake pad ; shoe linings)
- Wear due to grain friction

Parts subject to improper operation or insufficient maintenance.

Using the gearboxes without normal oil level or not complying with the transmission inlet specifications described in the user's manual.

Altering the maximum inlet torque (shear bolt system on PTO).

MACHINE	MAXIMUM ALLOWED INLET TORQUE	PROBABLE CAUSES THAT CAN ALTER THE MAXIMUM ALLOWED TORQUE
GTT 4010 BAGGER	2130N/m	Replacing the PTO with a PTO with no shear pin device installed.

Wheel nuts: After around 30 hours of running or after changing a wheel, wheel nuts must be retightened according to the torque values detailed in the manual (9 kgm = 90 Nm = 65 ft lbs. pie -point 7.g). Special care should be taken to the wheel nuts tightening if the machine has moved over paths or roads. Failure to follow these instructions may cause rim damage or lost of it.



AKRON[®]

Rosario de Santa Fe 2256 - X2400EFN San Francisco CBA, Argentina
Tel.: +54 3564 436777 ext 121 / +54 3564 498502 - E-mail: export@akron.com.ar - www.akron.com.ar



